

SEALED REQUEST FOR PROPOSAL (RFP)

ISSUE DATE: June 3, 2025
RFP NUMBER & TITLE: UCPUMW 25-1937, Special Event Equipment Rental
PROPOSAL DUE DATE & TIME: July 3, 2025, 2:00 p.m.
NOTE: Proposals received after the due date and time cannot be accepted.
PROPOSAL DELIVERY: Electronic file upload to eVA only
WORK LOCATION: [X] All Campuses [] Fredericksburg [] Stafford [] Dahlgren
COMMODITY CODE(S): 97741, 96234, 98172, 98143, 98136, 97732, 96260, 97735
PRE-PROPOSAL CONFERENCE: [X] Optional [] Mandatory [] N/A DATE & TIME: July 10, 2025 at 10:00 a.m.
PRE-PROPOSAL LOCATION: Eagle Village Executive Offices, Suite 480
1125 Emancipation Hwy., Fredericksburg, VA 22401
CONTRACT OFFICER: Kenneth Manahan EMAIL: kmanaha2@umw.edu
PERIOD OF CONTRACT: August 1, 2025 through July 31, 2026 with five, one-year renewal options that if exercised will extend the term of the contract through July 31, 2031.

In compliance with this Sealed Request for Proposal (RFP) and to all the conditions imposed therein, and hereby incorporated by reference, the undersigned firm offers and agrees to furnish the goods/services in accordance with attached signed proposal or as mutually agreed upon by subsequent negotiation. The undersigned firm hereby certifies that all information provided in response to this RFP is true, correct and complete.

By signing this proposal, you are certifying that you are an authorized representative of the offering firm and that the firm's principals or legal counsel have reviewed the Request for Proposal General Terms and Conditions and any Special Terms and Conditions. Any exceptions to the General or Special Terms and Conditions must be clearly identified in your proposal. No exceptions can be made to those General or Special Terms and Conditions that are mandated by law. If no exceptions are identified in your proposal, it is understood that the provisions will become a part of any final agreement.

THIS FORM MUST BE COMPLETED AND RETURNED WITH PROPOSAL

Name of Offering Firm: Ampa Entertainment, INC DBA Ampa Events
Address of Offering Firm: 6701 Janway Rd. Henrico VA, 23228
DSBSD Certification No.: SWAM 007285 Expiration Date: 1/18/2028
eVA ID: eVA-E84892 Tax ID: 54-1886661
Email: tedr@ampaevents.com Telephone: 804-358-5451
Website: www.ampaevents.com Fax:
Submitted By (Print Name & Title): Theodore C. Rubis President
Signature (In Ink): [Signature] Date: 6/24/2025

Dear Committee:

What's in a name? Some businesses just sprout up. True for Ampa also, but when it all started to develop in the 90's, much thought went into "What We Will Be?"

The Amphitheater in classical Greece was more than a place to enjoy comedy and tragedy. It was a place for communities, entertainment, thought, political and philosophical statements and a place to tell stories through drama. As the source of our name, it speaks to who we are at Ampa - a company that tells stories, drives messages, creates environments to drive a message, entertains and provide the production services and equipment for life's special moments. Ampa Events is a direct source for unique equipment, design and technical services.

For 29 years, Ampa Events has delivered excellence in the live event industry. This excellence started with our purposeful and thoughtful consideration of who and what we are as a company. Our longevity and success is perpetuated by: 1) Ampa's team - its knowledge, skills and drive; 2) the quality of Ampa's products - both inventory and services; 3) Ampa's ability to conceptualize events and communicate the approach, products and services clearly to our clients through business systems that provide itemized quotes and work orders; 4) Ampa's relevant experience as exemplified by a body of work spanning 21 years and various levels of complexity; and 5) methodology in performing the service - which starts with our focus on internal organization, policies and procedures and an incredible Customer Service Database Management system. These points shall be elaborated on while proceeding through the RFP response process.

To maintain this level of excellence, it is imperative that we employ great people. Ampa is committed to developing well paying jobs for career minded creative professionals. Jobs with living wages. We invest in recruiting on an ongoing basis to seek out the best and most talented college trained technical and artistic staff. Once we have found the right candidate, then we train the technician further, exposing them to the creative work we are called to execute and further advancing and molding their skills to apply effectively for live events. It is this level of commitment that is necessary to perpetuate our staffing needs for the future. With continued growth, Ampa is creating new positions to meet heightened demand.

Ampa's commitment to excellence is not limited to our people and the output of our fabulous scene shop. I am a student of business. A strong business structure is needed to keep it all running smoothly. Over 29 years, I have run a business that has thrived through several recessions without the need for layoffs. Ampa is a well financed business with superb business structure, procedures and support systems to perpetuate success for decades to come.

Through the following pages, I narrate Ampa's answers to each point in the RFP, inserted details examples and photos to illustrate our vast inventory and skill set. Ampa's skilled team, creativity, inventory, problem solving, years of experience, and close proximity to campus, and eVA SWaM business status is a winning combination for success.

Thank you for considering Ampa Events.

Sincerely,

Theodore C. Rubis
President, Ampa Events
6701 Janway Rd
Richmond, VA 23228

804-358-5451
www.ampaevents.com

General

What's in a Name?

Some businesses just sprout up. True for Ampa also, but when it all started to happen in the 90's, much thought went into What We Will Be?

Amphitheater, in classical Greece, is the embodiment of all production services for entertainment, thought, political and philosophical statements, a gathering place for communities. The association fit perfectly. Ampa, a complete source of production services and equipment for: all events, applied to support clients goals which may include a message, branding, heighten awareness of causes or just to have some fun.

History

For over **20** years, Ampa has played a role in life's most poignant moments. The first dance between a new husband and wife. Friends reuniting to share decades-old memories. A political hopeful launching a career. Colleagues uniting toward a shared mission. Volunteers raising money for a cause dear to their hearts.

Through it all, Ampa has relied on service as a cornerstone: working with you to pinpoint your needs and delivering.

Ted Rubis launched Ampa in 1985 as an entertainment-booking agency, building on his experiences with special events and his affinity for bringing people together. Responding to demand, Ampa began expanding its services. More importantly, it built a team of creative professionals who know how to use the resources at their disposal to serve your needs within your budget. Ampa can help you dazzle a large audience, bring crowds to their feet or discreetly fade into the background while those special moments emerge. It's up to you. As a Richmond-based company with team members in Tidewater and Washington, D.C., we're here to serve local, regional and national clients. Let us help you start celebrating, commemorating and bringing people together.

Ampa Events is a Richmond Base touring, design and event production services company, we're here to serve...

b. Identify the amount of sales your company has had (if any) during the last twelve months with each public Higher Education Institution within the Commonwealth of Virginia.

**Jan 2024 - June 2025**

Hampden Sydney College	\$106,342.95
Virginia Military Institute	\$ 46,807.00
University of Richmond	\$ 1,725.26
Va. Union University	\$ 1,100.00
University of Mary Washington	\$ 1,025.00
College of William & Mary	\$ 5,225.00
Randolph Macon College	\$ 2,694.00

c. Identify the location of your business indicating it is within 55-mile radius of UMW.



6701 Janway Rd
Henrico VA, 23228

Located on the North Side of Richmond, VA.

d. Provide documentation to substantiate proposed insurance is adequate to meet requirements of "Insurance" Special Term and Condition contained herein and to protect contractor's equipment from damage/destruction.



Ampa shall comply with, secure additional, and/or enhanced insurance policies in accordance with all specifications as needed. Axis Insurance Company has assured Ampa Events that all limits specified herein are attainable.

Vendors shall also comply or Ampa's policy will provide the university with the needed coverage.

[Ampa's Insurance on next page]

What we do

There are many event companies, meeting planners, a/v companies and lighting companies. What makes Ampa stand out is our focus on creativity along with the unification of all major event services under one roof. Ampa is not only creative in an artistic sense, but we are also creative in our approach to serving clients. Ampa's creative event design results in a maximization of our clients' budget, yielding the best bang for the buck. It is our extensive skill set as a company and our creative capabilities that gives us the ability to serve our clients in this manner. No matter what the budget, Ampa's creative approach to getting the job done and exceeding the client's expectations puts Ampa at the forefront in design and production for events and stage elements.

Insurance: Ampa is insured for all services with a \$2,000,000.00 liability policy. Additional Policy Binders are available as needed for high liability levels and work for the Federal Government.

Qualifications, Skills, Experience

Design & Fabrication	Prop & Stage Design	Directing
Carpentry	Artistry	Meeting Planning
Technical Building	Foam Carving	Scripting
Materials Analysis	Graphic Design	Technical Directors
Scenic Painting	Custom Gobo Design	Production Scheduling
Web Design	Color Study	Trade Show Services /
Hard Coat Technique	Wiring	Management
Drape	Auto Cad Design	Meeting & Event Directors
Seamstress	Renderings	Pre-production Services
Soft Goods	Auto Cad Design Shop	Technical Site Surveys
Vaccu-form	Audio/Visual	Concept Development
Lighting Design/Rigging		Event Management



Inventory

Ampa operates with over 30,000 square feet of time tested inventory which includes:

Stage Sets
Staging
Drape Systems
Props

Theme Decor
Scenery
Support Systems
Audio Visual

Lighting
Lounge Furniture
Designer Bars
Centerpieces

Social Focus

Ampa supports Made in the USA, and Green Practices including Sourcing Locally. We create jobs in the Richmond area through the manufacture of our stage sets, props, scenery and other goods and services, here, on site, in our Western Henrico Distribution center and through our purchase of Made in the USA products including Furniture from North Carolina, lighting systems, electrical systems and more.

a-b. Provide understanding of "Requirement for Criminal Background Check of Personnel Assigned by Contractor to perform work on UMW Property" and "Drug Free Workplace" Special Term and Condition contained herein.

**Ampa shall comply with Special Terms and Conditions**

As a prerequisite to employment with Ampa Events, all employees are required to provide a criminal background check. Information on file at Ampa to be provided as needed.

Additionally, Ampa shall institute company wide drug testing starting in 2016.



CERTIFICATE OF LIABILITY INSURANCE

DATE (MM/DD/YYYY)

2/25/2025

THIS CERTIFICATE IS ISSUED AS A MATTER OF INFORMATION ONLY AND CONFERS NO RIGHTS UPON THE CERTIFICATE HOLDER. THIS CERTIFICATE DOES NOT AFFIRMATIVELY OR NEGATIVELY AMEND, EXTEND OR ALTER THE COVERAGE AFFORDED BY THE POLICIES BELOW. THIS CERTIFICATE OF INSURANCE DOES NOT CONSTITUTE A CONTRACT BETWEEN THE ISSUING INSURER(S), AUTHORIZED REPRESENTATIVE OR PRODUCER, AND THE CERTIFICATE HOLDER.

IMPORTANT: If the certificate holder is an ADDITIONAL INSURED, the policy(ies) must have ADDITIONAL INSURED provisions or be endorsed. If SUBROGATION IS WAIVED, subject to the terms and conditions of the policy, certain policies may require an endorsement. A statement on this certificate does not confer rights to the certificate holder in lieu of such endorsement(s).

PRODUCER Foundation Insurance Group Inc 3190 Fairview Park Dr. Ste 104 Falls Church VA 22042	CONTACT NAME: Certificate Department PHONE (A/C, No, Ext): 703-527-8780 E-MAIL ADDRESS: certificates@figva.com		FAX (A/C, No): 703-532-8300
	INSURER(S) AFFORDING COVERAGE		
INSURED Ampa Entertainment Inc t/a Ampa Events 6701 Janway Road Henrico VA 23228	INSURER A : Axis Insurance Company		NAIC # 37273
	INSURER B : Accident Fund Insurance Co. of America		10166
	INSURER C :		
	INSURER D :		
	INSURER E :		

COVERAGES

CERTIFICATE NUMBER: 1072899902

REVISION NUMBER:

THIS IS TO CERTIFY THAT THE POLICIES OF INSURANCE LISTED BELOW HAVE BEEN ISSUED TO THE INSURED NAMED ABOVE FOR THE POLICY PERIOD INDICATED. NOTWITHSTANDING ANY REQUIREMENT, TERM OR CONDITION OF ANY CONTRACT OR OTHER DOCUMENT WITH RESPECT TO WHICH THIS CERTIFICATE MAY BE ISSUED OR MAY PERTAIN, THE INSURANCE AFFORDED BY THE POLICIES DESCRIBED HEREIN IS SUBJECT TO ALL THE TERMS, EXCLUSIONS AND CONDITIONS OF SUCH POLICIES. LIMITS SHOWN MAY HAVE BEEN REDUCED BY PAID CLAIMS.

INSR LTR	TYPE OF INSURANCE	ADDL INSD	SUBR WVD	POLICY NUMBER	POLICY EFF (MM/DD/YYYY)	POLICY EXP (MM/DD/YYYY)	LIMITS
A	<input checked="" type="checkbox"/> COMMERCIAL GENERAL LIABILITY <input type="checkbox"/> CLAIMS-MADE <input checked="" type="checkbox"/> OCCUR GEN'L AGGREGATE LIMIT APPLIES PER: <input checked="" type="checkbox"/> POLICY <input type="checkbox"/> PRO-JECT <input type="checkbox"/> LOC OTHER:			A1AMVA005-042895-15	2/28/2025	2/28/2026	EACH OCCURRENCE \$ 1,000,000 DAMAGE TO RENTED PREMISES (Ea occurrence) \$ 100,000 MED EXP (Any one person) \$ 5,000 PERSONAL & ADV INJURY \$ 1,000,000 GENERAL AGGREGATE \$ 2,000,000 PRODUCTS - COMP/OP AGG \$ 2,000,000 \$
A	<input checked="" type="checkbox"/> AUTOMOBILE LIABILITY <input checked="" type="checkbox"/> ANY AUTO <input type="checkbox"/> OWNED AUTOS ONLY <input type="checkbox"/> SCHEDULED AUTOS <input checked="" type="checkbox"/> HIRED AUTOS ONLY <input checked="" type="checkbox"/> NON-OWNED AUTOS ONLY			A1AMVA005-042895-15	2/28/2025	2/28/2026	COMBINED SINGLE LIMIT (Ea accident) \$ 1,000,000 BODILY INJURY (Per person) \$ BODILY INJURY (Per accident) \$ PROPERTY DAMAGE (Per accident) \$ \$
A	<input checked="" type="checkbox"/> UMBRELLA LIAB <input checked="" type="checkbox"/> OCCUR <input type="checkbox"/> EXCESS LIAB <input type="checkbox"/> CLAIMS-MADE DED <input checked="" type="checkbox"/> RETENTION \$ 0			A5AMVA005-042896-15	2/28/2025	2/28/2026	EACH OCCURRENCE \$ 1,000,000 AGGREGATE \$ 1,000,000 \$
B	WORKERS COMPENSATION AND EMPLOYERS' LIABILITY ANY PROPRIETOR/PARTNER/EXECUTIVE OFFICER/MEMBER EXCLUDED? (Mandatory in NH) If yes, describe under DESCRIPTION OF OPERATIONS below	Y/N	N/A	ARP12003382005	2/28/2025	2/28/2026	<input checked="" type="checkbox"/> PER STATUTE <input type="checkbox"/> OTHER E.L. EACH ACCIDENT \$ 1,000,000 E.L. DISEASE - EA EMPLOYEE \$ 1,000,000 E.L. DISEASE - POLICY LIMIT \$ 1,000,000
A	Equipment Floater			A1AMVA005-042895-15	2/28/2025	2/28/2026	Equipment \$100 Ded Comp \$1,000 Ded Coll
A	Hired Auto Physical Damage			A1AMVA005-042895-15	2/28/2025	2/28/2026	850,000 ACV

DESCRIPTION OF OPERATIONS / LOCATIONS / VEHICLES (ACORD 101, Additional Remarks Schedule, may be attached if more space is required)

CERTIFICATE HOLDER**CANCELLATION**

For Information Purposes Only

SHOULD ANY OF THE ABOVE DESCRIBED POLICIES BE CANCELLED BEFORE THE EXPIRATION DATE THEREOF, NOTICE WILL BE DELIVERED IN ACCORDANCE WITH THE POLICY PROVISIONS.

AUTHORIZED REPRESENTATIVE

© 1988-2015 ACORD CORPORATION. All rights reserved.

ATTACHMENT 1
POINT OF CONTACT INFORMATION SINGLE POINT OF CONTACT
RETURN THIS FORM WITH YOUR PROPOSAL PACKAGE

PRIMARY POINT OF CONTACT

CONTACT PERSON'S NAME	Ted Rubis
CELL PHONE NUMBER	804-283-3090
IS CELL PHONE CAPABLE OF RECEIVING TEXT MSGS?	YES
BEEPER/PAGER NUMBER	
TELEPHONE NUMBER – NORMAL WORKING HOURS	804-359-5451
TELEPHONE NUMBER – AFTER WORKING HOURS	804-284-3090
FAX NUMBER	804-358-0572
EMAIL ADDRESS	tedr@ampaevents.com

EMERGENCY POINT OF CONTACT

CONTACT PERSON'S NAME	Leslie Amason
CELL PHONE NUMBER	804-901-1745
IS CELL PHONE CAPABLE OF RECEIVING TEXT MSGS?	YES
BEEPER/PAGER NUMBER	
TELEPHONE NUMBER – NORMAL WORKING HOURS	804-358-5451
TELEPHONE NUMBER – AFTER WORKING HOURS	804-901-1745
FAX NUMBER	
EMAIL ADDRESS	lesliea@ampaevents.com

(Attachment 1 Continued)

INVOICING/PAYMENT POINT OF CONTACT

CONTACT PERSON'S NAME	Sandy Crowe
CELL PHONE NUMBER	804-513-9047
IS CELL PHONE CAPABLE OF RECEIVING TEXT MSGS?	YES
BEEPER/PAGER NUMBER	
TELEPHONE NUMBER – NORMAL WORKING HOURS	804-513-9047
TELEPHONE NUMBER – AFTER WORKING HOURS	N/A
FAX NUMBER	
EMAIL ADDRESS	ampabooks@ampaevents.com

ATTACHMENT 1 -- STATE CORPORATION COMMISSION FORM

Virginia State Corporation Commission (SCC) Registration Information. The bidder:

X is a corporation or other business entity with the following SCC identification number 04991147 -
OR-

_____ is not a corporation, limited liability company, limited partnership, registered limited liability partnership, or business trust **-OR-**

_____ is an out-of-state business entity that does not regularly and continuously maintain as part of its ordinary and customary business any employees, agents, offices, facilities, or inventories in Virginia (not counting any employees or agents in Virginia who merely solicit orders that require acceptance outside Virginia before they become contracts, and not counting any incidental presence of the bidder in Virginia that is needed in order to assemble, maintain, and repair goods in accordance with the contracts by which such goods were sold and shipped in Virginia from bidder's out-of-state location) **-OR-**

_____ is an out-of-state business entity that is including with this bid an opinion of legal counsel which accurately and completely discloses the undersigned bidder's current contracts with Virginia and describes why those contracts do not constitute the transaction of business in Virginia within the meaning of § 13.1-757 or other similar provisions in Title 13.1 or 50 of the Code of Virginia.

***NOTE*>>** Initial in the following space if you have not completed any of the foregoing options but currently have pending before the SCC an application for authority to transact business in the Commonwealth of Virginia and wish to be considered for a waiver to allow you to submit the SCC identification number after the due date for bids (the Commonwealth reserves the right to determine in its sole discretion whether to allow such waiver): _____

RETURN THIS FORM WITH YOUR PROPOSAL PACKAGE

ATTACHMENT 2 CONTRACTOR DATA SHEET
RETURN THIS COMPLETED FORM WITH YOUR PROPOSAL PACKAGE

QUALIFICATION OF CONTRACTOR: The Contractor must have the capability and capacity in all respects to fully satisfy all of the contractual requirements.

11x**YEARS IN BUSINESS:** Indicate the length of time in business providing this type of service.

29 **Years** _____ **Months**

IIIxREFERENCES: Indicate below a list of at least four (4) recent references, either commercial or governmental, for which this type of service has been provided. Include the date the service was furnished, and the name and address of the person the University has permission to contact, date of service, value or order, and contract number:

Name & Address	Contact Person	Email Address	Telephone Number	Description of Work & Date Completed
Brooke Rentals	Jim Brooke	jcb@brookerental.com	704-938-4807	
Vogue Flowers	Paul Christophakis	paulc@vogueflowers.com	804-353-9600	
Corcoran Caterers	Leslie Grimes	leslie@corcorancaterers.com	301-588-9200	
VMI	Command Master Sergeant Rubinstein	rubensteinsd@vmi.edu	540-464-7325	

- a. Describe your understanding and any experience with temporary structure permits through the Commonwealth of Virginia, Bureau of Capital Outlay Management.



Ampa shall facilitate the permitting process for county/city permits, such as building, fire, staging, etc. and provide safety packages that are required for all permitted tents and structures per locality requirements.

For additional information that illustrates the extent of our support for an event, please review the below Maryland Tourism Event.

UNIQUE STRUCTURES - Maryland Tourism Marketing Event

We love outdoor events. Nothing like a spring or fall day outside for a worthy cause or business goal. Maryland Tourism retained Ampa to design marketing solutions to "sell" International Travel Planners on Maryland as a destination at the IPW, the US Travel Associations premier event. This event is the perfect discussion of Form and Function delivered by Ampa. The designs must be attractive and affective in an advertising sense, but also must work in the potential most hostile environment for an outdoor event - an open space on the waterfront. Ampa's design team is collegiately trained with a good general understanding of structural design as taught in university theater programs. Ted Rubis, the owner of Ampa, took many physics and structural classes in undergrad - a sort of hobby. Combined, our team provided technical drawings to a qualified engineering firm for final approval and a Seal for the State of Maryland Building Code to validate the designs for building inspectors in advance of installation.

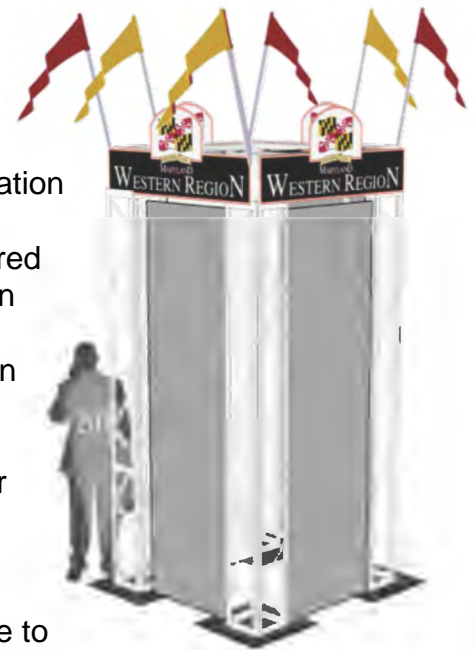

TRADITIONAL STRUCTURES

Also included here are photos of tented structures installed for various clients. (Roanoke College Capital Campaign, Richmond Children's Hospital lit for show conditions) Tents are a simple project. First we listened to the clients carefully to gain an understanding of the "big picture" and goals for the event. Then we conduct a site inspection and consider site factors for recommendations and installation. There are many practical matters to consider prior to install that affect functionality on site. Then we make a recommendation.

Tents are submitted to local building inspectors for permits and pre-approval and then site walkthroughs with inspectors are scheduled as needed.



Roanoke College Capital Kickoff

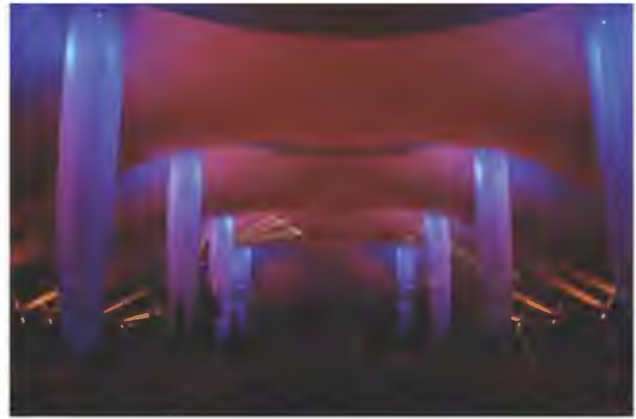

University of VA Family Weekend



Nace Gala



Children's Hospital Gala

b. Identify your proposed single point of contact, emergency point of contact and business (invoicing) point of contact (reference attachment 2) for all UMW special event rental services.

**Single Point of Contact:**

Theodore Rubis - President
Phone # - 804-358-5451
Cell Phone # - 804-283-3090
Fax # - 804-358-0572
Email - ted@ampaevents.com

Administrative Point of Contact:

Leslie Amason Director of Sales
Phone # - 804-358-5451
Cell Phone # - 804-901-1745
Fax # - 804-358-0572
Email - lesliea@ampaevents.com

Emergency Point of Contact:

Leslie Amason Director of Sales
Phone # - 804-358-5451
Cell Phone # - 804-901-1745
Fax # - 804-358-0572
Email - lesliea@ampaevents.com

Invoicing/Payment Point of Contact:

Sandy Crowe - Bookkeeper
Phone # - 804-358-5451
Cell Phone # - 804-513-9047
Fax # - 804-358-0572
Email - books@ampaevents.com

c. Provide three references for contracts with similar size, scope, capabilities. Include the contract number, the agency name, the point of contact (Contracts and/or actual Customer), phone number, and email address, along with date of service and value of the order (reference Attachment 3, Contractor Data Sheet).



1. Virginia Military Institute - Command Master Sergeant Rubenstein-
rubensteinsd@vmi.edu - 540-464-7325 Job#14219 - 3/8/24 - Budget \$20,012.50

2. Hampden Sydney College - Cameron Cary - ccary@hsc.edu - 434-223-6000 -
Job #14461 - 10/25/24 - Budget \$106,342.95

3. College of William & Mary - Laura Talbot - lmtalbot@wm.edu - 757-221-1184
-Job #14800 - 6/6/25 - Budget \$5,225

d. Identify your direct experience and expertise in convention, event, or hospitality industry.

There are many good production companies with great technical skills, people and deep pockets for the latest in high tech AV equipment. This is part of UMW's need. Creativity is the other half of the equation. But, even here, there is much to consider.

For 29 years, Ampa Events has creatively provided solutions for client needs. Yes, creative can be defined as artistic. And, yes, we are artistic. But it is the creative minds that are best suited for complex productions and problem solving. It is the creative minds at Ampa that will provide the true lifting and toting for the event.

Ampa sells itself as "a direct source of unique inventory, technical and design services." Yes, we have huge inventories in house, however, we will call on other SWAM vendors and tap our long standing relationships with expert companies in other areas such as High Def LED Screens for indoor installation and outdoor use via trailered units.

e. Describe ability to provide special event rental services for small or large, multi-location events. Be specific in detailing the event from beginning to end including ability to provide set-up and take-down services.



Ampa's ability to provide special event rental services, is clearly documented in over 29 years of successful and profitable business operations. Our body of work is published in our website which chronicles work for small and large projects including, rental pickup, rental drop-off, rental with complete installation, and the complete design and execution of complex projects. Also posted, find specialty technical services for large and small projects including audio visual, sound & lighting , specialty installation, and finally also documented is a history of creative solutions for clients of all types.



Rental and Technical Services

Example of providing special event rental services.

Ampa was hired by Corcoran Caterers to convert a construction zone in a Reston, VA cloud storage facility into a well decorated VIP reception for executive guests and public officials. In the before and after pictures you will see rental equipment services, general installation services, technical installation services including illumination lighting, decorative lighting and AV services, design and decorating services, and more. During the build up to execution Ampa provided site survey and assessment services, technical and decorative design services.

General event management which included interaction with facilities, personnel, timeline management and a level of professional is result in the smooth execution of a highly complicated project.

Beginning to end service provided

This example included installation planning 6 months in advance. Ampa communicated weekly with the construction foreman for updates on construction schedule and times for site inspection. Onsite planning then took place with building managers, construction representatives, the end client, and Corcoran Caterers. Ampa was the catalyst for moving the projects forward the 6 months period prior to the production. During completion of construction Ampa provided timelines and updated these timelines regularly. The timelines were paramount in organizing and notifying all key numbers involved in the execution giving everyone a clear understanding of what was to be done and at what time. These timelines included fabrication schedules for custom components ordered by the client to be completed in a timely manner by Ampa's scene shop as well as warehouse and personnel schedules for employees to load trucks and depart for installation.



Installation began the day before the event date. Ampa dispatched a crew of 8 including the president of the company who was the account manager and designer for the project, 2 carpenters, 2 lighting/AV technicians, and several university trained theater technicians. Installation was completed in an 8 hour period for client to review before close of business. Technicians remained on site for operation and management of production during the event day. The event started at 6:00pm and concluded at 9:00pm.

Guest enjoyed themselves so much that the event continued for an additional hour. Ampa's 24ft box truck arrived at 8:00pm according to preplanned schedule with technical crew for takedown and removal and offsite in 3 hours with a crew of 6. Post-Event the equipment was unloaded, checked individually and returned to stock. Ampa's return to stock system includes a thorough evaluation of equipment to note if any repairs are necessary prior to renting. Additionally, Post-Event Ampa calls all clients for a review of the program in a customer service survey.

f. Describe in detail warranty given on all equipment and service.



Ampa's designs are 100% itemized and thus provide for a 100% itemized shipping bill of lading. Should a product be delivered or not operate as designated the equipment cost shall be refunded.

g. Identify any certifications and licenses that you the contractor and/or employee(s) may currently hold.



Certified Rigging

h. Describe the training, expertise, and supervision of personnel employed by the contractor that will be assigned to service this contract.



Question answered in our company Resume pg. 19

j. Provide resumes of key personnel that will be assigned to this tasking.

[Ampa's Resumes on next page]

Our Core Team - Bios

Theodore Rubis - President of Ampa Events

When Ted was working his way through pharmacy school at VCU-MCV, he never imagined that the entertainment business he launched as a side project would become a full-time passion.

A native of Richmond, Ted dove into studies at Virginia Tech and graduated from the VCU/MCV School of Pharmacy, returning to school later to focus on business, economics, finance and accounting.

Throughout his career, Ted found himself being called upon by organizations to help with creative projects. Along the way, he studied stage craft as a hobby. As a young professional he worked on a number of charity events to raise money for the Virginia Museum of Fine Arts. Looking back, he can see how his academics and leadership pursuits all came together in building a creative, successful and thriving event company -- and a talented team to carry out Ampa's mission.

With over 25 years of creative projects under his belt, Ted has honed his skills in design, showmanship, decorating, lighting and professional event management. He describes himself as a technical production manager, but his creativity and knowledge takes him far beyond as a designer and senior producer. He will tell you that adding value to client events through Ampa's creativity and driving messages with production services is the "fun" that keeps him going.

He may no longer be helping patients at the pharmacy counter, but after more than 25 years, Ted's perfected a different kind of chemistry -- one that creates lasting memories and unforgettable moments for clients from all walks of life.

Stephanie Rubis - Vice President & Corporate Attorney

Stephanie provides crucial services to Ampa in the review of contracts, employee relations, human resources and, in general, management of Ampa Events. As a corporate lawyer during the first half of her career and later a prosecutor, Stephanie guides Ampa in all contract and legal matters.

Sandy Crowe - Bookkeeper

Sandy has been with Ampa Events since December 2012 as an office Manager/Bookkeeper as well as Payroll Manager. She lives in the country in Charles City County with her gardening husband. Below is her skillset:

- 35+ years of office-related experience in a variety of atmospheres with consistently increasing responsibilities in areas of management.
- Accounts Payable/Accounts Receivable, Billing Invoicing, Producing purchase order and other bookkeeping experience PeachTree and Quickbooks programs
- "Hands-on" experience in all areas of office operations to include word processing, processing of forms development, phone duties, office manager, company representative in professional social activities.
- Attended – J. Sargeant Reynolds Community College, VA –Accounting and Management Courses
- Attended - Camden County College, Camden, NJ - -Business Degree Courses

Leslie Amason - Director of Sales & Senior Event Designer

For over 30 years, Leslie has produced special events for corporate, non-profit organizations, and PGA tournament events. Though her BA degree is in the world of fashion, she decided after college that her creative passion was with the event industry. Her dedication and obsession for detail to each event shows through her expertise in every event. Leslie's unique southern personality has a way of connecting with each client and has won the hearts of many.

James Meekins III - Graphic Designer

James has a BFA in Graphic Design from VCU. He has used his foundation in art to create designs for events and internally. He has been a key player in our marketing and creative schemes. He also brings in a vast experience in the print and web industry. His support in presentations and designs and his natural skills as a photographer, writer and artist are invaluable to our needs and that of our clients.

Other Skilled and Experienced Theater Technicians drawn from VCU, Richmond Ballet and other local Theaters as overhire as needed.

- a. Provide a internet address for your firm's online special event rental catalog, if available, or promotional material that provides photographs, descriptions, quantities available and pricing for offered items.



www.ampaevents.com

<http://www.ampaevents.com/party-rentals>

- b. Describe seating options including the maximum number of uniform chairs that can be accommodated with one order. Include seating specifications, colors, etc. Provide descriptive literature, specifications and pictures of seating options being offered.

As seen in photos below of VA Highway Safety Memorial Dedication and a political event at the capitol, Bulk Chairs are available in White, Black, Gray and Brown (resin and metal frame) We do not own these chairs, but prove subcontracts at Market Costs with no mark up. Over 10,000 are available.



- c. Describe staging options to include various sizes, styles, skirting, etc. Provide descriptive literature, specifications, and pictures of staging being offered.

Standard Stage Deck - Wood & Carpeted



**4x4ft Stage Decking
wood
carpeted**

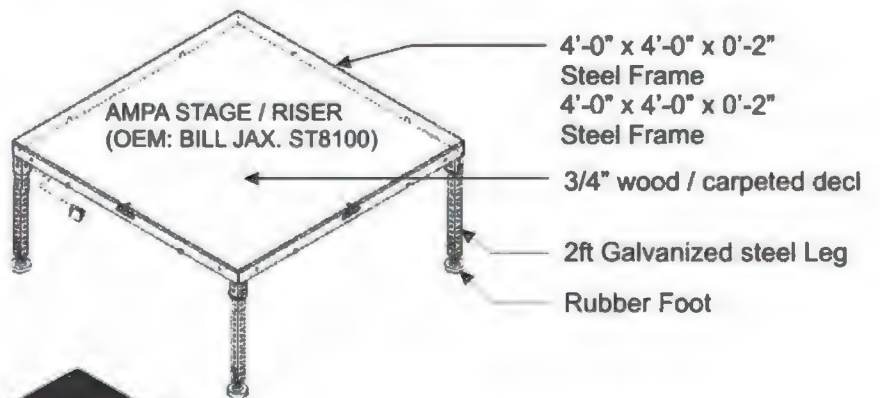

**2x4ft Stage Decking
(wood)**



- d. Describe table options to include various sizes and styles. Provide descriptive literature, specifications and pictures of tables being offered.

Standard Tables



4',5' & 6' Round Tables



Cocktail High 42" w/ Metal Stem



Cocktail Low 30" w/ Metal Stem



Rectangle Tables 6' x 24"



Rectangle Tables 8' x 24"



Serpentine 5' Tables

Farm Tables



French Country Dining Table
6' x 30" x 40"



Java Dining Table
6' x 30" x 36"
Mahogany or Natural



Lit Stage Deck

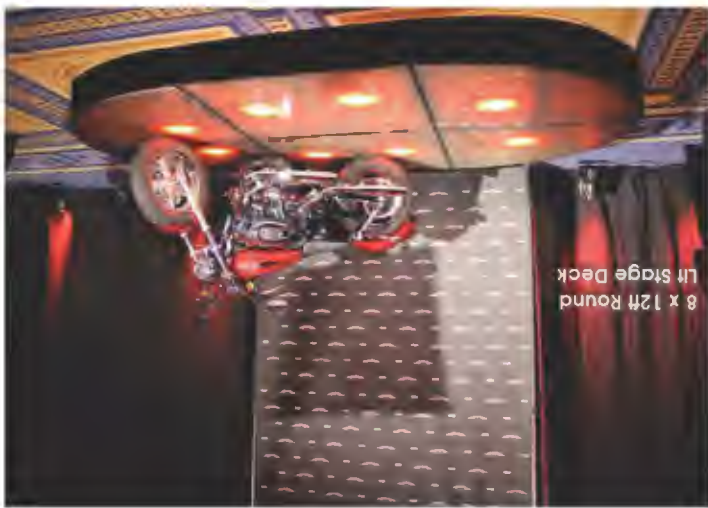

Lit Stage or Dance Floor 4'x4' Section w/ LED - 4'w x 2'h x 4'd

Lit ¼ Circle Stage or Dance Floor 4'x4' Section w/ LED - 4'w x 2'h x 4'd

Stage Rails, 4' Section

Stage Rails, 8' Sect

Stage Stairs, Wood 2'



Acrylic Tables



Acrylic Communal Table, High
96" x 42" x 24"



Acrylic Dinner Table, Low
48" x 30" x 96"



Acrylic Dinner Table, High
48" x 42" x 96"



Acrylic Square Table, Low
48" x 30" x 48"



Acrylic Dinner Table, Low
48" x 30" x 96"



Acrylic Square Table, High
48" x 42" x 48"

e. Describe tent options to include various sizes and styles and associated cost. Provide descriptive literature, specifications and pictures of tents being offered.

Tents



10' x 10' Frame-Type Tent = \$140



15' x 15' Frame-Type Tent = \$299
 15' x 30' Frame-Type Tent = \$425
 15' x 45' Frame-Type Tent = \$525



10' x 20' Frame-Type Tent = \$295



20' x 20' Frame-Type Tent = \$380



10' x 30' Frame-Type Tent = \$410
 10' x 40' Frame-Type Tent = \$520
 10' x 50' Frame-Type Tent = \$635



20' x 30' Frame-Type Tent = \$520

Tents



30' x 60' Frame-Type Tent = \$1,160

- 20' x 40' Frame-Type Tent = \$635
- 20' x 50' Frame-Type Tent = \$755
- 20' x 60' Frame-Type Tent = \$870
- 20' x 70' Frame-Type Tent = \$985



40' x 100' Push Pole-Type Tent = \$2,200



30' x 30' Frame-Type Tent = \$780



40' x 40' Frame-Type Tent = \$1,350



30' x 40' Frame-Type Tent = \$920

Tents



40' x 40' Push Pole-Type Tent = \$2,200



40' x 60' Push Pole-Type Tent = \$1,860



40' x 60' Frame-Type Tent = \$1,730
40' x 80' Frame-Type Tent = \$1,970



40' x 80' Push Pole-Type Tent = \$1,990



40' x 80' Push Pole-Type Tent = \$2,070



40' x 60' High Peak Push Pole-Type Tent = \$1,760



60' x 100' Push Pole-Type Tent = \$3,465

Tents



60' x 120' Push Pole-Type Tent = \$3,935
 60' x 140' Push Pole-Type Tent = \$4,410
 60' x 160' Push Pole-Type Tent = \$5,030



60' x 60' Push Pole-Type Tent = \$2,675

Tent Accessories



60' x 60' Push Pole-Type Tent = \$2,675



60' x 60' Push Pole-Type Tent = \$2,675
 Artificial Turf per sq. ft. = \$0.40
 Double Glass French Doors = \$260



Pedestal Fan = \$38

Tent Accessories



Entrance Marquee = \$140



Sateen Pole Covers - each = \$15



Flexible Marquee 7'x7' / section = \$140
 Globe Lights String (8) = \$80
 Miniature Bulb String = \$80
 Outdoor Flooring - Tents or walkways per sq. ft. = \$1.15



Sateen Pole Drapes - each = \$28



Sateen Tent Liner - Call for Price



Picket Fence Panel - 72" x 42" = \$24

Tent Accessories



Sidewalls - Clear per 20' section



Sidewalls - Solid White per 20' section



Sidewalls - Window per 20' section
Street Lights - 4 globes



Tent Furnace 400,000 BTU - Indirect propane heat with ductwork (propane is additional)



Tent Heater 170M BTU



Tent Heater 52,000 BTU - Electric 220V



Tent Heater 90M BTU
Uplighting (Par Cans) per 300w light
White 4-light Chandelier



- f. Describe portable sanitation unit options to include various sizes and styles and associated cost. Provide descriptive literature, specifications, and pictures of comfort stations being offered.

Ampa shall partner with a VA Small or Minority owned business to provide portable toilet. Product will be passed on to client at Cost with No Mark Up.

- g. Describe portable generator options to include various sizes and power capabilities. Provide descriptive literature, specifications, and pictures of generators being offered.

***Delivery and Environmental fees are not included**



Portable Generator, 6.5-6.9 kW



Portable Generator, 9.6-9.9 kW



Generator, 19-29 KVA

h. Provide information on other items your firm provides for special event rental.

FURNITURE & BARS

Sofas
Chairs
Barstools
Tables
Charging Stations & Tables
Benches & Ottomans
Bars
Bar Accessories
Pillows

DECOR BY THEME

1920s Gatsby Roaring 20's
1950s
1960s
1970s
1980s
007
African
Alice in Wonderland
American Diner
Arabian
Awards
Back to the Future
Backdrops
Bar Hire
Bavarian
Baywatch
Beach & Buffet
Beauty & the Beast
Big City
Black & White
Bollywood
British
Burlesque
Caribbean
Carnival
Carpet Walkways
Casino
Celebrations
Charlie and the Chocolate
Factory
Christmas
Christmas - All Theme Ideas

Christmas - Christmas Market
Christmas - Contemporary
Christmas - Rustic
Christmas - Santa's Grotto
Christmas - Traditional (Red, Gold & Green)
Christmas - Victorian
Cinderella
Cinema
Circus
Cirque Du Soleil
Classical
Come Dancing
Cruise
Cuban
Theme Casino
Fairground
Fairytale
Farm
Farm-To-Table
Festival
Fiesta
Fishing
Football
Fourth of July
Food and Drink
Football
Frames
Frozen
Game Show
Games
Gangsters
Garden
Gentlemen's Club
Giant Make-Believe
Gold
Grand Prix
Grease
Greek
Halloween
Heaven
Hell
Hollywood
Horse Racing

Hunting
Illuminated
India
Industrial
Industrial Chic, Vintage
International
Italian
Jungle
Las Vegas
Life-Size Figures
London
Mardi Gras
Medieval
Mid-Century Modern
Military
Moroccan
Musical Instruments
Narnia
Nautical
Neon
New Orleans
New Years Eve
New York
Night at the Museum
Night Club
North Pole
Oktoberfest
Old Hollywood
Olympics
Oriental
Outdoor
Oversized
Paris
Parisian Burlesque
Park
Peter Pan
Pirate
Police
Prehistoric

Pub
 Racing
 Regency
 Rock & Roll
 Rodeo Rio
 Roman
 Royal
 Safari & Lost City
 Seaside
 Scenery
 School
 Secret Agent
 Seven Deadly Sins
 Shabby Chic
 Sherlock Holmes
 Ski Lodge
 Soft Furnishings
 Space & Sci-Fi
 Space
 Spandex
 Spanish
 Sports & Tailgate
 Speakeasy
 Star Wars
 Steam Punk
 Storybook
 Street Festival & Food Trucks
 Superheroes
 Sweet Treats
 Television & Film
 Tiki
 Titanic
 Toga Party
 Toyland
 Transportation
 Travel - Modern
 Travel - Vintage
 Trees
 Trees, Plants & Foliage
 Tropical
 Under The Sea
 Urban / Street
 Venetian
 Victorian
 Wartime

Washington & Patriotic
 Western Tex-Mex
 White Party
 Winery
 Winter Wonderland
 Wizard of Oz
 Wizard School
 Woodstock
 Zen

STAGE SETS

Hard Sets & Drape Kits
 Contemporary Sets

PARTY RENTALS

Chairs
 Tables
 Stage & Dance Floor
 Rope, Stanchion & Carpet
 Linens
 Chargers, China & Flatware
 Glassware
 Charging Stations & Tables
 Novelty Food
 Arches, Columns & Umbrellas

CENTERPIECES

Floral
 Lanterns, Candles, &
 Candelabra
 Light Up & Prop
 Silks
 Urns & Containers
 Retail

LIGHTING & AV

Conventional
 Intelligent
 LED
 Special Effects & Confetti
 Support Gear, Controllers,
 Truss
 String Lights, Lanterns,
 Chandeliers
 Gobos

Audio Visual & Podiums
 For Sale

ACCESSORIES

Columns, Pedestals & Lamp
 Posts
 Screens
 Foliage
 Urns & Containers
 Charging Stations & Tables
 Umbrellas

ENTRANCES

PERGOLAS & TRELIS

STATUES & PROPS

Statues & Sculptures
 Cutouts
 Props
 Signs & Letters

DRAPE

Fabrics
 Kits

FLAGS & BUNTING

WEDDING DECOR

Service Sets, Pergolas &
 Trellises

Drape

Weddings Chandeliers &
 String Lights

Gobos

Wedding Collections - Pure
 White
 Wedding Collections - Rustic

GAMES

Arcade & Table Games
 Carnival & Other Games
 Inflatables & Rock Wall
 Casino

Reference website for additional products and services: www.ampaevents.com/party-rentals



Mahogany Cocktail High with
Pedestal
24" x 42" x 24"



Mahogany Communal Table with
Pedestal Legs
96" x 42" x 24"



South Seas Pub Table
36" x 42" x 36"



Farm Tables & Communal Tables



Knotty Pine Dining Tables have multiple leg options



Hand Buffed Rich Chestnut Stained Knotty Pine



Knotty Pine Dining Table with Metal Legs
96" x 30" x 40"



Knotty Pine Dining Table with Spindle Legs
96" x 30" x 40"



Knotty Pine Dining Table with White Spindle Legs
96" x 30" x 40"



Butcher Block Communal Table w/ Chestnut Stain
96" x 30" x 24"
96" x 42" x 24"



Butcher Block Cafe Table w/ Chestnut Stain
24" x 30" x 24"



Butcher Block Cocktail High Table w/ Chestnut Stain
24" x 42" x 24"

Stage Skirting & Accessories



- Box Pleat Stage Skirt 1' Black - 12'w x 1'h = \$20
- Box Pleat Stage Skirt 2' Black - 12'w x 1'h = \$25
- Box Pleat Stage Skirt 3' Black - 12'w x 1'h = \$25
- Box Pleat Stage Skirt 4' Black - 12'w x 1'h = \$45

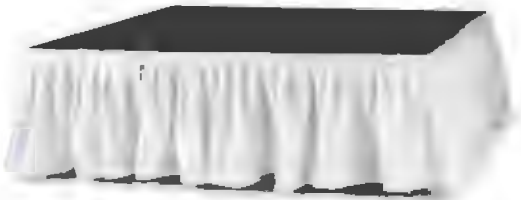

- Box Pleat Stage Skirt 2' White - 12'w x 1'h = \$45



- Stage Stairs - 42"w x 24"h x 42"d = \$125
- Wooden Stage Stairs 2' - 48" x 24" x 24" = \$25.00



- Stage Deck, Cross Bracing - 48"w x 42"h = \$2.50

Stage Rails, 4' Section = \$25

Stage Rails, 8' Section = \$35

Stage Stairs, Wood 2' = \$20

Curved Stage Deck



Left Curve Stage Deck
4'x2' - \$65





Right Curve Stage Deck
4'x2' - \$65



1/4 Circle Stage Deck
4'x4' - \$65

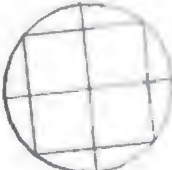
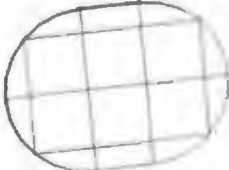

				Delivered & Install		
		Wood Deck	Carpet Deck	Lit Deck		
1.	 8 x 8ft Round Stage w/ Black Skirting	\$675	\$775	Call For Price		
2.	 12 x 12ft Round Stage w/ Black Skirting	\$975	\$1175	Call For Price		
3.	 12 x 16ft Round Stage w/ Black Skirting	\$1775	\$1975	Call For Price		
4.	 16 x 16ft Round Stage w/ Black Skirting	\$2175	\$2375	Call For Price		

- a. Describe timeframe for set-up and take-down of equipment.



Timeframe for setup and take down is specific to the equipment as well as the venue and loading conditions these and other variables are carefully considered when an account manager is estimating labor requirement for each production.

Labor requirements are determined by the natural flow of the event. Firstly, a driver is required, secondly the venue and loading circumstances are evaluated, thirdly the requirements of installations are evaluated. Venues may provide a 2hr install period thus requiring more labor and installation. Finally, ampa evaluates the specific equipment and the skill level of labor required to install specific equipment.

Ampa's goal is a scientific approach for all process in business for over 2 decades during our second decade we began studying and collecting information on the required to install various products in our inventory. In our digital database there is a field that indicates the amount of time required to install a 12x12ft square designer bar (2 carpenters = 1.5hrs) The same is true for stage sets and commodity equipment such as tables and chairs. All processes at ampa are design accurate estimating and execution for great customer service.

- b. Describe consultation and guidance that may be provided to UMW in determining exact needs for specific events and locations. Describe ability to accommodate requests for site visits to make recommendations and suggestions concerning equipment needed.



Ampa Skill may be applied as follows:

1. Stage Craft and Design Service

The complete development of a stage design. From concept development, to hand drawings, renderings and an end product with appropriate engineering stamps ready for approval by the committee.

2. Fabrication Services

Our full service theater style scene ship is capable of fabrication in standard and unique materials. Integrating AV services in the stage design and general functionality of the flow of persons on and off stage plus accommodations for technical need are what a Thinking Company does naturally. We are a thinking company with a full understanding of production services and run of show.

3. Technical Site Evaluation

Drawing on over 20 years of experience building projects from the parking lot up, the committee will find our technical knowledge extremely valuable. This is a knowledge base across all disciplines.

c. Describe in detail cancellation requirements.



30 Days cancellation notice preferred. Special conditions may be negotiated with each contract.

Weather policy: Outdoor events and the weather are the complete responsibility of the client. ampa reserves equip personnel and support services specifically for each project in advance thus earning the majority of our fee during the advance planning design period of production design services.

d. Describe invoicing procedure and timelines. Provide sample invoice with proposal.



Ampa shall track all aspects of the production via QuickBooks Accounting software under the watchful eyes of our veteran bookkeeper, Sand Crowe. Quickbooks shall generate all desired consolidate accounting services, and post event reports. All invoices shall accompany paperwork. Bookkeeper is available as needed.

1. General Event Design Production Service Standard Procedure:
 - a. 50% deposit up front
 - b. Final Payment due upon arrival
2. Custom Fabrication Invoicing Procedure:
 - a. 50% deposit up front
 - b. Final Payment due upon arrival

Ampa is happy to accommodate UMW Procurement needs.

- e. Unanticipated events may be held with little to no notice. Describe the expected turnaround time for events at UMW and how tight deadlines are met.



Some of the most extreme cases with quick turnaround times are every 4 years during Inaugurals. Routinely operatives from both parties call Ampa with less than a week's notice for patriotic, decor for stage backdrops for general use. All of which must be quickly uploaded for invoicing and fast contract turnaround to allow for individual truck loading and scheduling of personnel while we prefer more notice several events were planned in 2016 with less than 24hr notice. One event in particular had there production a day away had our company on file and didn't let us know until 11pm at night for a 6am departure (thats 7hrs later). Upon receipt of the call Ted activated production staff to immediately open the warehouse and load trucks for departure for 6am install. Ampa has a unique advantage in servicing short notice programs in the depth and breath of our inventory as well as through our online eCommerce ordering system. Quick orders may be placed by rentals website with contract turnaround in 24hrs upon receipt of contract, trucks are loaded and personnel are scheduled.

- f. Provide any documented standard operating procedures that would mitigate risk to UMW.



Ampa shall provide 100% itemized proposals with complete equipment lists and designs; itemized entertainment, parking and other services as requested by client.

1. Our Database is an itemized sales system.
2. Our Database creates a pick list.
3. Inventory is pulled to holding bays and checked by manager.
4. The Order is then loaded on truck.
5. Managers check truck for accuracy of the order.

*10% additional equipment is provided along with additional general support gear.

- g. Describe your staffing plan for delivery, set-up, operation, take-down and removal of equipment (numbers of employees, types of employees, responsibilities of employees).



Example of Staffing Plan: VMI MidWinter Dance

Ampa packed and provided a design for VMI's MidWinter Dance on a 24ft truck of theme decor & lighting. During the production meeting a team of 6 full-time theatre technician along with managers were briefed via a detailed installation floorpan. Truck arrived onsite at 8am and project was completed by 4pm with internal staff.

General labor for the install of massive amount of massive amount of tables and chairs for any project is conducted by hired labor while managers and technicians supervising the whole install. A significant quantity of labor is ordered to allow for a complete installation by at least 1hr in advance or as designated by client before doors open.

Sample Quote



PROPOSAL

Page 1 of 6

ampa events

6701 Janway Rd, Henrico, VA 23228
info@ampaevents.com

Client: MGM National Harbor

Contact: Aedrian Aquino
Address: 101 MGM National Avenue
National Harbor, MD 20745
Phone: (702) 845-7057
Email: AEAQUINO@mgnnationalharbor.com

Job #: 14602
Agent: Ted Rubis

Event Site:
Event Date: Monday, 01/27/25
Load In: 01/27/25
Load Out: 01/27/25

Lunar New Year - VIP Dinner

I. Entrance: Drape Swages (2 sided & 2 sections w/ 1 for each door), Cut Wood Columns, Gold Bamboo in Urn w/ Fronds:

	<u>Qty.</u>	<u>Retail</u>	<u>%</u>	<u>Extended</u>	<u>Total</u>
1. Bamboo: Golden Bamboo Size: x 96" x	14	\$2.50		\$2.50	\$35.00
2. Urns: Black Metal Geo Urn (42") with Palms and Bamboo Size: 16 x 96 x 16 Color: black	2	\$175.00		\$175.00	\$350.00
					
3. Pipe and Drape: Panne Velvet, Red 14' H x 10' W Size: x x Color: red	2	\$110.00		\$110.00	\$220.00
					
4. Pipe and Drape: Panne Velvet, Red 14' H x 10' W Size: x x Color: red	2	\$110.00	60.00%	\$44.00	\$88.00
					
5. Pipe and Drape: Panne Velvet, Red 14' H x 10' W Size: x x Color: red	2	\$110.00		\$110.00	\$220.00
					
6. Pipe and Drape: Panne Velvet, Red 14' H x 10' W Size: x x Color: red	2	\$110.00	60.00%	\$44.00	\$88.00
					

Prices herein are valid for 10 days. Inventory items, Labor rates and trucking rates are subject to availability at the time the signed contract and deposit are received at Ampa.

06/26/25

Sample Quote





AMPA EVENTS
MGM National Harbor - Lunar New Year - VIP Dinner - Monday, 01/27/25

Page 2 of 6

7. Decor: Tassel, Medium Gold Size: x x Color: gold	6	\$5.00	\$5.00	\$30.00	
8. Chinese Lucky Paper Fan Kit 8-16" Size: x x	2	\$20.00	\$20.00	\$40.00	
9. Oriental Lantern Stand 8ft Size: 2x8 Choose lanterns separately	4	\$100.00	\$100.00	\$400.00	
10. Chinese Silk Lanter 16" Size: x x	6	\$20.00	\$20.00	\$120.00	
11. Screen: Oriental Bifold, Wood Frame & Gold Square Pattern Size: 24 x 95 x 24	1	\$225.00	\$225.00	\$225.00	
12. Column: Oriental Gold Square Pattern Black Frame Size: x x	2	\$375.00	\$375.00	\$750.00	
Entrance: Drape Swages (2 sided & 2 sections w/ 1 for each door), Cut Wood Columns, Gold Bamboo in Urn w/ Fronds Subtotal:				\$2,566.00	

II. Stage Set - Custom Design & Build: Center Wall 8x10x2ft (NOT White) w/ Round Detail; Chinese Wood Lattice Elements x 4; Banner Walls 2x8; Live Plants and Tall Orchid Trees:

	<u>Qty.</u>	<u>Retail</u>	<u>%</u>	<u>Extended</u>	<u>Total</u>	
1. Stage Set: Wealth Character w/Roof & Stoop 8x10x2 Size: 8x10x2	1	\$1,995.00		\$1,995.00	\$1,995.00	
2. Screen: Oriental Bifold, Wood Frame & Gold Square Pattern Size: 24 x 95 x 24	6	\$225.00		\$225.00	\$1,350.00	

Prices herein are valid for 10 days. Inventory items, Labor rates and trucking rates are subject to availability at the time the signed contract and deposit are received at Ampa.





06/26/25

Sample Quote



AMPA EVENTS
MGM National Harbor - Lunar New Year - VIP Dinner - Monday, 01/27/25

Page 3 of 6

3. Oriental Lantern Holder Size: 2x8 Choose lanterns separately	4	\$100.00		\$100.00	\$400.00
4. Centerpiece: Floral Stem Holder 72" Size: x 72 x Color: black Select floral separately	2	\$85.00		\$85.00	\$170.00
5. Red Orchid Stem 36" Size: x 36 x	88	\$3.50		\$3.50	\$308.00
6. Pipe and Drape: Polyknit, Chocolate 14' H x 10' W Section Size: 120 x 168 x 2 Color: BROWN	4	\$100.00		\$100.00	\$400.00
7. Chinese Silk Lanter 16" Size: x x	12	\$20.00		\$20.00	\$240.00
8. Floral: Orange Orchid, Phalaenopsis Stem 35" Size: x 35 x Color: Orange 35" Orange Real Touch Phalaenopsis Orchid	88	\$0.00		\$0.00	\$0.00
9. Bamboo Tree 5ft Size: 5ft	6	\$50.00	100.00%	\$0.00	\$0.00

Stage Set - Custom Design & Build: Center Wall 8x10x2ft (NOT White) w/ Round Detail; Chinese Wood Lattice Elements x 4; Banner Walls 2x8; Live Plants and Tall Orchid Trees Subtotal: \$4,863.00

III. Lighting Design, Full Room with 36 UpLights :

	Qty.	Retail	%	Extended	Total
1. Lighting Design: Full Room, Large Size: x x	1	\$3,000.00		\$3,000.00	\$3,000.00



Sample Quote



AMPA EVENTS
MGM National Harbor - Lunar New Year - VIP Dinner - Monday, 01/27/25

Page 4 of 6

2. Lighting: LED MIRAGE QA Wireless, Black Size: x x Color: black	24	\$0.00
--	----	--------

Lighting Design, Full Room with 36 UpLights Subtotal: \$3,000.00

IV. Table Linens:

	<u>Qty.</u>	<u>Retail</u>	<u>%</u>	<u>Extended</u>	<u>Total</u>
1. Linen Budget See notes for details	40	\$65.00		\$65.00	\$2,600.00

Table Linens Subtotal: \$2,600.00

V. Bar: Mahogany, or Oriental w/ Gold Lattice and Wealth Symbol. All bars are the same price. Counter Centerpieces found in Centerpiece section:

	<u>Qty.</u>	<u>Retail</u>	<u>%</u>	<u>Extended</u>	<u>Total</u>
1. Bar: Oriental Lattice & Wealth Symbol Gold, Red, Black Size: 96 x 42 x 30	3	\$575.00		\$575.00	\$1,725.00



Bar: Mahogany, or Oriental w/ Gold Lattice and Wealth Symbol. All bars are the same price. Counter Centerpieces found in Centerpiece section Subtotal: \$1,725.00

VI. Room at Large Decor - Wealth Symbol Wood Stain:

	<u>Qty.</u>	<u>Retail</u>	<u>%</u>	<u>Extended</u>	<u>Total</u>
1. Screen: Oriental Round Wealth Symbol Gold Size: 8	6	\$325.00		\$325.00	\$1,950.00
2. Urns: Black Metal Geo Urn (42") with Palms and Bamboo Size: 16 x 96 x 16 Color: black	6	\$175.00		\$175.00	\$1,050.00



Prices herein are valid for 10 days. Inventory items, Labor rates and trucking rates are subject to availability at the time the signed contract and deposit are received at Ampa.

06/26/25

Sample Quote



AMPA EVENTS
MGM National Harbor - Lunar New Year - VIP Dinner - Monday, 01/27/25

Page 5 of 6

3. Sandbags: 1/4 Size for Florals Weights Size: x x	0	\$2.50	\$2.50	\$0.00
4. Sandbag: Black 25lb, Ampa Blue Handle Size: x x Color: black/blue	0	\$2.50	\$2.50	\$0.00



Room at Large Decor - Wealth Symbol Wood Stain Subtotal: \$3,000.00

VII. Delivery, Labor and Service:

	<u>Qty.</u>	<u>Retail</u>	<u>%</u>	<u>Extended</u>	<u>Total</u>
1. DELIVERY	1	\$575.00		\$575.00	\$575.00
2. Fuel Surcharge Size: x x	1	\$50.00		\$50.00	\$50.00
3. Budget for Labor at 30% Size: x x Proposed / Estimated budget. Shall be adjusted with final order.	1	\$6,800.00	25.00%	\$5,100.00	\$5,100.00

Delivery, Labor and Service Subtotal: \$5,725.00

**VIII. EXTRAS: Live Plant, Additional Lantern Holders, Sago Palm Silks
(Red or Black Banjo Drape is \$10.00 a panel vs velvet):**

	<u>Qty.</u>	<u>Retail</u>	<u>%</u>	<u>Extended</u>	<u>Total</u>
1. Live Plant Budget Size: x x Plants by Each or By Total Budget. See notes for additional info	48	\$60.00		\$60.00	\$2,880.00
2. Oriental Lantern Stand 8ft Size: 2x8 Choose lanterns separately	6	\$100.00		\$100.00	\$600.00



Prices herein are valid for 10 days. Inventory items, Labor rates and trucking rates are subject to availability at the time the signed contract and deposit are received at Ampa.





06/26/25

Sample Quote



AMPA EVENTS
MGM National Harbor - Lunar New Year - VIP Dinner - Monday, 01/27/25

Page 6 of 6

3. Chinese Silk Lanter 16" Size: x x	12	\$20.00		\$20.00	\$240.00
					
4. Foliage: Palm, Sago (Low at 12x24in) Size: 12 x 24 x 12 Color: green	18	\$15.00	100.00%	\$0.00	\$0.00
					
5. Drape: Panel: Panne Velvet, Red 14ft Size: x x	12	\$35.00		\$35.00	\$420.00
					
6. Drape: Panel: Banjo, Black 8' Size: 4' x 8' Color: black Drape only. 48"x94"	33	\$10.00	100.00%	\$0.00	\$0.00
					
7. Support: Wood Bases w/ Holes	1	\$2.50	100.00%	\$0.00	\$0.00
					

EXTRAS: Live Plant, Additional Lantern Holders, Sago Palm Silks (Red or Black Banjo Drape is \$10.00 a panel vs velvet) Subtotal: \$4,140.00

Subtotal Nontaxable	\$8,591.50
Subtotal Taxable	\$21,894.00
Subtotal	\$30,485.50
6% Sales Tax	\$1,313.64
Retail Total	\$31,799.14
Courtesy Deduction	<\$2,866.50 >
Grand Total	\$28,932.64

06/26/25

Prices herein are valid for 10 days. Inventory items, Labor rates and trucking rates are subject to availability at the time the signed contract and deposit are received at Ampa.

Sample Invoice



AMPA EVENTS
6701 JANWAY RD
HENRICO, VA 23228
54-1886661

Invoice

DATE	INVOICE NO.
1/3/2025	5-28792

Ph 800-358-5451 - Fax 804-358-0572
WWW.AMPAEVENTS.COM

PAID
02/14/2025

MGM National Harbor
Aedrian Aquino
1010MGM National Ave
National Harbor, MD 20745

SHIP TO

Rep	P.O. No.	Ampa Job	Terms	Event Date
TCR	C11328059	14602	50% Deposit Due Now	1/27/25

DESCRIPTION	QTY	RATE	AMOUNT
Rental Fees for Product for the LUNAR NEW YEAR VIP EVENT - 1/27/25	1	21,894.00	21,894.00
Labor for Installation and Removal	1	5,100.00	5,100.00
Delivery and Fuel sur-charge	1	625.00	625.00

PLEASE REMIT TO:
Ampa Events
6701 Janway Road
Henrico, VA 23228

Subtotal	\$27,619.00
Sales Tax (6.0%)	\$1,313.64
Total	\$28,932.64
Payments/Credits	-\$28,932.64
Balance Due	\$0.00

- h. Understanding Commonwealth of Virginia Higher Education requirements for Commencement Support for the same or similar timeframes, describe your capacity to meet that demand signal.



Production timeframes and maintaining appropriate schedules are independent of event type setup parameters including short installation on quick turnaround projects are managed by advanced planning and the development of an execution program to meet client's goals.

- i. Describe any proposed subcontracting arrangements and expectations.



DC Rental

Products: Linens, China, Flatware, Glassware, Bulk Decorative Ballroom Chairs

ALL PRODUCTS HEREIN PROVIDED AT MARKET COSTS W/ NO ADDITIONAL MARKUP TO DC RENTAL'S RETAIL PRICE OTHER THAN DELIVERY & LABOR

Brooks Rentals - Vienna, Va

Products: Tents, bulk chairs, tables

ALL PRODUCTS HEREIN PROVIDED AT MARKET COSTS W/ NO ADDITIONAL MARKUP

- j. Describe your inclement weather procedures.



Safety first is the most important SOP. Each type of equipment may have different requirements. High wind action plans are developed for some project. Most equipments, such as tents, are installed to withstand weather events. The best approach is to have a clear understanding of a day by which the event is CALLED and moved indoors. In this day of instant access to weather information, a surprise storm is a rare occurrence.

In general Action Plans are develop for each event in the planning phase. Staff may be planned for in advance with a clear scope of duties while onsite during the event.



- a. Complete pricing schedule attached (attachment 3) filling in pricing for all items that your company can provide.



See Attachment 3 on page 51

- b. Identify any offered discounts, rebates, opportunities for internships, sponsorships.



The following elements shall be provided with a 10% courtesy rate:
Lounge Furniture, Designer Bars, and Theme Decor.

- c. Identify any add-on charges proposed in complete detail (shipping by order, by load; by delivery; split order add-on charges; cancellation fees; credit card fees). Any add-on charges that are not identified in your original proposal will not be permitted under a resulting contract. It is imperative that you identify all potential add-on charges for consideration.



Credit Card Fee = 3%
 Delivery by Truck Size - per round trip
 24ft and 16ft = 275.00
 Econo Van and Pick up Truck = 175.00
 Cancellation Fee - we do not have an added fee, but this is governed by the negotiated contract terms prior to signing a contract.

ATTACHMENT 3-- PRICING SCHEDULE

RETURN THIS FORM WITH YOUR PROPOSAL PACKAGE

The Contractor agrees to provide the services in compliance with the scope of work for each specific line item/services at a firm fixed price for the period of this agreement as follows.

In any instance where the contractor cannot provide the required services within an acceptable timeframe, the University reserves the right to purchase these services on the open market.

The quantities are estimated quantities used for evaluation purposes only. The University reserves the right to purchase those services actually needed and in quantities as required by the University regardless of whether such total quantities are more or less than those shown.

Item No	Description	Daily Rental	Quantity	Unit	Total
	TENTS and Canopies (Provide, Install, and Remove)				
	To include poles and concrete anchors, courtyard tents (all require concrete anchors)				
1	Tents, 10' x 10', Standard Tent	\$ 145		Each	\$
2	Tents, 10' x 10', High Peaked	\$		Each	\$
3	Tents, 15' x 15'	\$ 330			
4	Tents, 15' x 30'	\$ 465		Each	\$
5	Tents, 20' x 20'	\$ 425		Each	\$
6	Tents, 30' x 30'	\$ 850		Each	\$
7	Tents, 30' x 40'	\$ 995		Each	\$
8	Tents, 30' x 45'	\$ 920		Each	\$
9	Tents, 30' x 50'	\$		Each	\$
10	Tents, 30' x 60'	\$ 1250		Each	\$
11	Tents, 30' x 75'	\$		Each	\$
12	Tents, 40' x 80'	\$ 2100		Each	\$
13	Tents, 60' x 100'	\$ 3800		Each	\$
14	Tents, 80' x 100'	\$		Each	\$
15	Tents, 80' x 210"	\$		Each	\$
16	Clear Top Tent, 30' x 30'	\$		Each	\$
17	Clear Top Tent, 30' x 40'	\$		Each	\$
18	Clear Top Tent, 30' x 45'	\$		Each	\$
19	Clear Top Tent, 30' x 50'	\$		Each	\$
20	Clear Top Tent, 30' x 60'	\$		Each	\$
21	Clear Top Tent, 30' x 30'	\$		Each	\$
22	Clear Top Tent, 30' x 75'	\$		Each	\$
23	Clear Top Tent, 30' x 90'	\$		Each	\$
24	Clear Top Tent, 40' x 45'	\$		Each	\$
25	Clear Top Tent, 40' x 50'	\$		Each	\$
26	Clear Top Tent, 40' x 60'	\$ 2992.50		Each	\$
27	Clear Top Tent, 40' x 80'	\$ 3375		Each	\$
28	Clear Top Tent, 40' x 100'	\$ 3765		Each	\$
29	Clear Peak Tent, 10' x 10'	\$		Each	\$
30	Clear Peak Tent, 10' x 20'	\$		Each	\$
31	Clear Peak Tent, 15' x 15'	\$		Each	\$
32	Clear Peak Tent, 20' x 20'	\$		Each	\$

33	Clear Peak Tent, 20' x 30'	\$		Each	\$
34	Clear Peak Tent, 20' x 40'	\$		Each	\$
35	Sail Cloth Tent, 45' x 44'	\$		Each	\$
36	Sail Cloth Tent, 45' x 64'	\$		Each	\$
37	Sail Cloth Tent, 45' x 84'	\$		Each	\$
38	Sail Cloth Tent, 45' x 104'	\$		Each	\$
TENT Accessories (Provide, Install, and Remove)					
39	Concrete Anchors	\$ 12.00		Each	\$
40	Concrete Covers	\$		Each	\$
41	Tent Pole Covers	\$ 20.00		Each	\$
42	Tent Liner for Each Size Tent	\$		Each	\$
43	Tent Lights, Bistro – Black and White	\$		Each	\$
44	Tent Lights, Lanterns, Japanese 12", 16", 20" and 24"	\$ 15-20.00		Each	\$
45	Tent Fan	\$ 110		Each	\$
46	Tent Fan - 12"	\$		Each	\$
47	Tent Fan – 18"	\$		Each	\$
48	Drum Fan, 24"	\$		Each	\$
49	Tent Gutter	\$ 15.00		Each	\$
TABLES (Rental, Set-up, Breakdown)					
50	Banquet Rectangular 4' x 30"	\$ 6.90		Each	\$
51	Banquet Rectangular 6' x 30"	\$ 8.10		Each	\$
52	Banquet Rectangular 8' x 30"	\$ 8.60		Each	\$
53	Banquet Rectangular 6' x 18"	\$		Each	\$
54	Banquet Rectangular 8' x 18"	\$		Each	\$
55	Banquet Rectangular 8' x 30" Children's Table	\$		Each	\$
56	Banquet Round 3'	\$ 7.80		Each	\$
57	Banquet Round 4'	\$ 12.50		Each	\$
58	Banquet Round 5'	\$ 15.50		Each	\$
59	Banquet Round 6'	\$ 16.00		Each	\$
60	Cocktail Rounds Tall and Standard Heights 24"	\$ 10.75		Each	\$
61	Cocktail Rounds Tall and Standard Heights 30"	\$ 11.85		Each	\$
62	Square 2', Standard and High Top	\$ 25.00		Each	\$
63	Square 4', Standard	\$ 35.00		Each	\$

64	Square 5', Standard	\$ 45.00		Each	\$
65	Serpentine 8'	\$ 11.00		Each	\$
66	Timberwood Farm Table, 4' x 8'	\$ 145.00		Each	\$
67	Timberwood Benches for Farm Table	\$		Each	\$
68	King Table, 4' x 8' Rectangular Table	\$		Each	\$
CHAIRS (Rental, Set-up, Breakdown)		\$		Each	\$
69	Padded Garden, White, Black and Natural	\$ 4.00		Each	\$
70	Folding Black, White, and Tan	\$ 1.50		Each	\$
71	Chivari Barstool, Black and Natural, mahogany,	\$ 17.00		Each	\$
72	Chivari Black, Gold, Silver, Mahogany, and White	\$ 17.00		Each	\$
73	Set Up/Knock Down of Chairs	\$		Each	\$
STAGE SECTIONS, 4' X 8' (PROVIDE, INSTALL, AND REMOVE)					
74	Stage, 12" High	\$ 50.00		Each	\$
75	Stage, 32" High	\$ 75.00		Each	\$
STAGE EQUIPMENT (PROVIDE, INSTALL AND REMOVE)					
76	Staging (Risers 4 x 4)	\$ 35/45.00		Each	\$
77	Staging Steps	\$ 162.50		Each	\$
78	Black Astroturf Covering for Stage	\$.60 sq ft		Each	\$
79	4' Guard Rails for Staging	\$ 25.00		Each	\$
80	ADA Access Ramps by the Foot	\$ 125.00		Each	\$
STAIRS (PROVIDE, INSTALL AND REMOVE)					
81	Stairs, 12" High	\$ 50.00		Each	\$
82	Stairs, 32" High	\$ 75.00		Each	\$
PIPES AND DRAPES (RENTAL ONLY)					

83	10' High Black, Navy Blue and Royal Blue, White	\$ 70.00		Each	\$
84	12' High Black, Navy Blue and Royal Blue, White	\$ 80.00		Each	\$
85	20' High Black, Navy Blue and Royal Blue, White	\$ 125.00		Each	\$
STANCHIONS (RENTAL ONLY)					
86	36" High, without Rope	\$ 15/25.00		Each	\$
87	White Plastic with White Plastic Chain	\$		Each	\$
STANCHIONS CHROME PORTA POST					
88	6' Section Red and Black Velour Rope	\$ 15.00		Each	\$
89	8' Section Red and Black Velour Rope	\$		Each	\$
ARCHES (PROVIDE, INSTALL AND REMOVE)					
90	Wood	\$ 97.50		Each	\$
COLUMN (PROVIDE, INSTALL AND REMOVE)					
91	33"	\$ 45.00		Each	\$
92	46"	\$ 45.00		Each	\$
93	56"	\$ 25.00		Each	\$
94	76"	\$ 65.00		Each	\$
95	Stage Façade, 3' x 4'	\$		Each	\$
96	Bar Top for Rectangular Table and Skirting, 6'	\$		Each	\$
SCREEN (PROVIDE, INSTALL AND REMOVE)					
97	6 Panel Bi-Fold Screen, White	\$		Each	\$
LOUNGE FURNITURE (PROVIDE, INSTALL AND REMOVE)					
98	Sectional Full Sofa	\$ 292.50		Each	\$
99	Sectional Love Seat	\$ 180.00		Each	\$
100	Sectional Arm Chair	\$ 210.00		Each	\$

101	Sectional Ottoman	\$		Each	\$
FLOORING (PROVIDE, INSTALL AND REMOVE)					
102	Deck Flooring	\$ 1.55 sq ft		Each	\$
103	Dance Floor	\$ 1.75 sq ft		Each	\$
104	25' Red Carpet	\$ 50.00		Each	\$
105	50' Red Carpet	\$ 75.00		Each	\$
MISCELLANEOUS (PROVIDE, INSTALL AND REMOVE)					
106	6' Bar Tops for Rectangular Tables	\$		Each	\$
107	Portable Bar	\$ 150.00		Each	\$
BAR					
108	Portable Acrylic Bar	\$ 575.00		Each	\$
COMMENCEMENT STAGING	See requirements for staging along with diagrams (Reference Attachment 7 to this RFP)	\$		Each	\$
DELIVERY		(Per Order)	(Flat Rate)		
109	Delivery and Pickup Charge, Flat Rate, for Chairs, Tables, Pipe and Drapes, Stanchions, and other items as Required.	\$ 575.00	\$	Events	\$
TOTAL NET PRICING:					\$
110	Informational Pricing: The Contractor offers to the University the following discount from the contractor's standard published list price in effect at the time of the rental for all items not listed above % - Listed Price				

ATTACHMENT 4 -- SMALL BUSINESS SUBCONTRACTING PLAN
MUST BE COMPLETED AND RETURNED WITH PROPOSAL

All small businesses must be certified by the Commonwealth of Virginia, Department of Small Business and Supplier Diversity (DSBSD) by the due date of the solicitation to participate in the SWaM program. Certification applications are available through DSBSD online at <http://sbsd.virginia.gov>.

DEFINITIONS:

“Micro Business” means a business that is a certified Small Business under the SWaM Program and has no more than twenty-five (25) employees and no more than \$3million in average annual revenue over the three-year period prior to their certification.

“Small business” means a business independently owned and controlled by one or more individuals who are U.S. citizens or legal resident aliens, and together with affiliates, has 250 or fewer employees, or average annual gross receipts of \$10 million or less averaged over the previous three years. One or more of the individual owners shall control both the management and daily business operations of the small business. *Note: DSBSD-certified women- and minority-owned businesses shall also be considered small businesses when they have received DSBSD small business certification. (Code of Virginia, § 2.2-4310)*

“Woman-owned business” means a business that is at least 51% owned by one or more women who are U.S. citizens or legal resident aliens, or in the case of a corporation, partnership, or limited liability company or other entity, at least 51% of the equity ownership interest is owned by one or more women who are U.S. citizens or legal resident aliens, and both the management and daily business operations are controlled by one or more women. *(Code of Virginia, § 2.2-4310)*

“Minority-owned business” means a business that is at least 51% owned by one or more minority individuals who are U.S. citizens or legal resident aliens, or in the case of a corporation, partnership or limited liability company or other entity, at least 51% of the equity ownership interest in the corporation, partnership, or limited liability company or other entity is owned by one or more minority individuals who are U.S. citizens or legal resident aliens, and both the management and daily business operations are controlled by one or more minority individuals. *(Code of Virginia, § 2.2-4310)*

Bidder Name: Theodore Rubis

Preparer Name: James Meekins **Date:** 6/26/2025

INSTRUCTIONS:

- A. If you are certified by the Department of Small Business and Supplier Diversity (DSBSD) as a small business, complete only Section A of this form. This shall not exclude DSBSD-certified women-owned and minority-owned businesses when they have received DSBSD small business certification.
- B. If you are not a DSBSD-certified small business, complete Section B of this form. For the bid to be considered and the bidder to be declared responsive, the bidder shall identify the portions of the contract that will be subcontracted to DSBSD-certified small business in Section B.

ATTACHMENT 4 (CONT'D)

Section A

If you are certified by the Department of Small Business and Supplier Diversity (DSBSD), are you certified as a:

Check All That Apply: Micro Business Small Business Woman-Owned Business Minority-Owned Business

DSBSD Certification No.: SWAM 007285 Expiration Date: 1/18/2028

COMMITMENT TO SMALL BUSINESS

As an eVA small business, Ampa is committed to working with other small business and we shall seek out support from local Fredericksburg business per the event needs.

ATTACHMENT 6

SUBCONTRACTOR APPROVAL REQUEST

No portion of the work (including equipment) shall be subcontracted to another firm or individual **without prior written consent** of the University of Mary Washington. In the event that the contractor desires to subcontract some part of the work specified herein, the Contractor shall furnish the University with the names, qualifications and experience of their proposed subcontractors for agency approval. The primary contractor shall, however, remain fully liable and responsible for the work performed by its subcontractor(s) and shall assure compliance with all requirements of the contract.

List proposed subcontractor(s), including name, address, contact person, and type of work to be performed under this contract below:

Company and Individual Name and Address	Contact Person and Phone Number	Type of Work to be Performed	Type of Equipment Proposed Subcontractor will Provide	Qualifications of Proposed Subcontractor
Brooke Rental Center, Inc 321 Mill St. NE Vienna VA 22180 #720632	James C Brooke 703-938-4807 JCB@brookerental.com	Installation & Take Down	Tents & Chairs	

ADDENDUM
June 17, 2025

ADDENDUM NO. 1 TO ALL OFFERORS:

Reference – Request for Proposals: #UCPUMW 25-1937
Date Issued: June 3, 2025
For Delivery to: University of Mary Washington, Commonwealth of Virginia
Proposal Due Date: July 3, 2025

This addendum consists of one (1) pages.

Questions from Offerors:

- Question:** The stage under the 40X tent is tiered...do you know the length of the stage?
UMW Response: The length is 76 feet wide.
- Question:** The height of the stage in the back and each tiered by how many inches resulting in being what height in the front?
UMW Response: Tiers are 6" and the front level is 6" off the ground. Due to the bowl shape of the ground, the height varies across each level, but everything is taken off the front portion of the stage.
- Question:** The VIP tent...does that have any type of ground covering or no flooring of any type?
UMW Response: There is no flooring of any type.

END OF ADDENDUM NO. 1

Kenneth Manahan
Sr. Contract Officer
Procurement Services
University of Mary Washington
Phone: (540)654-1006

RFP UCPUMW 25-1937 Addendum No. 1 (and all addenda) should be acknowledged and included in the RFP submittal package.

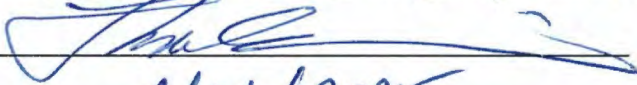
NAME OF OFFERING FIRM: Amya Events Amya Entertainment
NAME OF OFFEROR REPRESENTATIVE: Theodore C. Rubit President Inc
OFFEROR SIGNATURE: 
DATE: 6/26/2025