

Standard Contract

**Contract #UCPUMW 25-1937
Special Event Equipment Rental**

This contract, between Ampa Entertainment, INC dba Ampa Events, hereinafter called the “Contractor”, and the Commonwealth of Virginia, University of Mary Washington, called the “University” or “UMW”, shall become effective upon execution of this document by both parties.

WITNESSETH that the Contractor and the University, in consideration of the mutual covenants, promises and agreements contained herein, agree as follows:

PERIOD OF CONTRACT: October 1, 2025 through September 30, 2026, with five (5) one-year renewal options

CONTRACT DOCUMENTS: The contract shall consist of the following documents *in order of precedence*, all of which are incorporated herein by reference, and constitute the “contract documents”:

1. This signed Contract;
2. Any addenda and the original solicitation, RFP #UCPUMW 25-1937, dated June 3, 2025 to include:
 - a. The Statement of Needs
 - b. The General Terms and Conditions
 - c. The Special Terms and Conditions;
3. The Contractor’s proposal dated June 26, 2025 including all attachments.

Any contractual claims shall be submitted in accordance with the contractual dispute procedures set forth in the Commonwealth of Virginia Purchasing Manual for Institutions of Higher Education and their Vendors.

I. SCOPE OF SERVICES: The Contractor agrees to provide the following services:

- A. As required by the University, the Contractor shall provide goods and services for equipment rental, including outdoor tents, chairs, staging, tables, linens, generators, heaters, props, furniture, temporary structures, labor, insurance, supervision, incidentals, and other related supplies, services, furniture, and equipment, on an as-needed basis for special event rental services to the University.
- B. Location of Contractor’s Service Center must be within a 75-mile radius of the UMW’s Main Campus, 1301 College Avenue, Fredericksburg, VA 22401.
- C. Implementation and adherence to proper safety and health precautions to protect, at a minimum, all of its work, employees, the public and University personnel, students, and guests.
- D. Equipment/Structures:
 - i. Contractor will deliver in-stock equipment in accordance with delivery expectations of the end user. Delivery time on any non-stock equipment will be detailed to the end-user prior to order placement.
 - ii. All equipment shall conform to any and all established manufacturer or industry standards and/or legally required laws, ordinances, and/or codes and shall be uniform, clean, superior quality, operable with no broken parts, and the same color within each ceremony/location. UMW will at its sole discretion determine if equipment is acceptable for use.
 - iii. The Contractor shall have in current stock, or available for rental at the required time, all equipment in sizes bid. Tents larger than 30’ x 30’ may be either framed or center pole.
 - iv. Contractor shall provide an event site diagram which includes rental equipment layouts, if needed. The contractor will provide verbal and written instructions for the use of equipment.

- v. The Contactor will be provided a site visit prior to delivery of rental equipment at no additional charge to the University.
 - vi. All rentals will include set-up, break-down, and return of the site to its original condition unless the University requests otherwise.
 - vii. The Contractors shall adhere to all manufacturer, University and Commonwealth of Virginia requirements related to anchoring systems, side panels, lighting, exits, locations of heaters, generators, etc.
 - viii. The Contractor shall be responsible for monitoring weather conditions and may be required to cancel the erection/use of the structure should wind speed exceed manufacturer and Commonwealth requirements.
 - ix. Damages to listed equipment caused by the Contractor's negligence or nonfeasance shall be repaired at no cost to the University.
- E. Requirements regarding Site Plans include, but are not limited to:
- i. Temporary Structure Site Plans shall indicate distances from other occupied Buildings and Structures and the Use Group of these structures, if within 40 feet of the permit requested Temporary Structure.
 - ii. Indicate on Site Plan(s) other site occurring/affecting items, such as: general site slope(s) and ground cover, sidewalks, paths, stairs, ramps, wheelchair egress/access, roadways, drives, trees, bushes, landscaping, bodies of water, other temporary structures and site improvements.
 - iii. For further information and for information on other temporary structures, the Contractor may be required to contact the Division of Engineering and Buildings (DEB) Lead Reviewer assigned to UMW to discuss the specific data and supporting documents which will be required.
- F. Licenses, Permits and Certifications:
- i. Contractor will be required to meet any/all license requirements stated within the contract at such time as the University has a project that needs to be fulfilled.
 - ii. Contractor must have personnel that are knowledgeable of "temporary structure permits" through the Commonwealth of Virginia and shall be trained and qualified to handle work of this type.
 - iii. Contractor shall be certified by the manufacturer or have established experience on all equipment, systems and supplies on which the firm will provide. The Contractor will provide documentation on manufacturer certification and/or references as requested by UMW throughout the duration of the contract.
 - iv. The University shall be responsible for obtaining permits for temporary structure through DEB. However, the Contractor may be required to assist the requesting Department with the following supporting documents for tents and other amusement devices:
 - 1) Site Plan, showing tent location and adjacent structures
 - 2) Floor Plans, with Exits shown
 - 3) Floor Plans, with Furnishing Layouts/Setups shown (e.g., tables, chairs, stages, food service, dance floor, etc.)
 - 4) Certificate of Conformance with NFPA 701 for Flame Resistance, if applicable.
- G. Failure to Perform or Deliver:
- i. Failure of the Contractor to deliver in the timeframe indicated may result in the University cancelling any order (or part of any order) without payment to the Contractor, and the University will not be held responsible for any restocking fee or penalty.
 - ii. Failure to provide equipment that has been scheduled and confirmed in advance shall be considered a failure to perform and may result in cancellation of the contract. All requests are understood by the Contractor to be dependent on availability. If the Contractor is unable to provide the scheduled equipment more than three (3) times during each contract year, the contract may be cancelled.
 - iii. Repeated failure to furnish materials on time, poor quality or unacceptable performance on the part of the contractor shall be deemed sufficient cause for cancellation of the agreement by the University.
- H. Contractor Employees:
- i. Contractor shall be responsible at all times for the actions and work of its employees. The contractor shall enforce strict discipline and good order among event personnel. UMW reserves the right to

- require the contractor to remove any employee whose behavior is deemed as unprofessional or objectionable.
- ii. The contractor shall provide a sufficient number of qualified supervisors and employees to physically inspect, monitor or supervise the Contractor's employees, ensuring adherence to the work schedule and quality of work.
 - 1) One supervisor shall be appointed as main contact for the University's Contract Administrator.
 - 2) The supervisor shall be able to speak and read English fluently.
 - 3) It is expected that this person will report to the Contract Administrator or his/her designee daily when work is being performed under this contract.
 - iii. Employee Conduct: The supervisor shall be responsible for the conduct and performance of the Contractor's employees, in addition to compliance with the following rules:
 - 1) Contractor's employees appearing to be under the influence of alcohol or drugs shall not be permitted on University premises.
 - 2) No loud, boisterous or rude conduct shall be permitted.
 - 3) Contractor's employees shall not use or tamper with office machines nor use University telephones at any time.
 - 4) No smoking or vaping on UMW premises.
 - 5) No radios, no portable music sources, nor the use of residence hall televisions shall be permitted.
 - 6) No unauthorized personnel: The Contractor's employees are not to be accompanied in their work areas or on the premises by acquaintances, family members, or any other person unless said person is an authorized Contractor employee performing work under the contract.
 - iv. Contractor shall assign a coordinator to review all billings to assure complete and accurate information and to act as contact person for the University.
 - v. Contractor employees are required to wear uniforms to designate their affiliation at all times while on University property. Uniforms will contain the Contractor's name and the person's name designated on the upper portion of the shirt. Uniforms must remain consistent for proper identification purposes. The Selected Firm's personnel must have a photo ID with their name, company name, and be worn above the waist at all times. The University requires such identification for security precautions and access will be prohibited if University personnel do not recognize the identification.
- I. Communications:
- i. The Contractor shall designate a single company representative as the contact person for all rental requests. The designated representative shall advise UMW of equipment availability and shall confirm each rental.
 - ii. The Contractor shall identify and provide a contact person and a day and evening telephone number for emergency communications resulting from severe weather, faulty equipment, and all problems associated with the rental. If a change in the company representative occurs, the Contractor shall immediately notify the UMW representative ordering the equipment and/or UMW's Contract Administrator.
 - iii. Contractor will provide an answering service available for emergencies 24-hours a day, seven days a week.
- J. Pricing Schedule:
- i. The quantities shown in the Pricing Schedule are for the purposes of evaluation only; the one-day event rental prices (unit price) will set the baseline for pricing for future purchase orders.
- K. Damages/Insurance
- i. The Contractor is responsible for damages resulting from equipment failure that may cause personal injury to an Individual or to university facilities or equipment. The Contractor agrees to purchase such insurance over and above the University's stated minimum commercial general liability coverage that they consider necessary to protect their equipment from damage or destruction during the term of this contract. The Contractor also agrees that the University shall have no obligation for payment of damages of any nature to equipment provided. Contractor further understands and agrees that no employee of UMW, other than the designated Procurement Services department representative, is authorized to sign any rental or other agreement that contains terms and conditions other than those contained in this solicitation or in a purchase order issued against this solicitation, and that any

- signature of a University employee shall be interpreted as the University's acknowledgement of delivery only.
- ii. In addition to the above, the Contractor shall provide to the Purchasing Agent (Procurement Services) a Certificate of Insurance indicating that the Contractor has in force the coverage specified in the Terms and Conditions of this Solicitation/Contract.
- L. Ordering Process:
- i. Develop clear, concise, and professional quality written quotes for each event for review and acceptance by UMW.
 - 1) Upon receipt of a written request from UMW, the contractor shall furnish a written description of the scope of services to be provided, ensuring mutual understanding and agreement of the services/work to be performed. The written description shall also include an estimate of the costs to complete the service, a set-up and pick-up date, expressed as either a definite date or the number of days after receipt of UMW's eVA purchase order.
 - a) Quoted prices for a specific event shall include any and all additional costs/fees associated with product procurement (such as, but not limited to, freight/shipping cost, crating fee, eVA transaction fee, processing fee, etc.).
 - ii. Upon approval of the quote by the Events Office, an eVA purchase order will be issued as authority to proceed with the work. The eVA purchase order shall incorporate the contractor's quote as a "not to exceed" cost and the agreed upon delivery and pick-up time.
 - iii. Request for rentals may be made by telephone, fax, or letter against a valid UMW Purchase Order Agreement.
 - iv. The Contractor shall perform no work that would result in exceeding the dollar limitation of the eVA purchase order without first having obtained written approval from the Agency.
 - v. The University will make every effort to provide the Contractor notice of such events no later than one (1) month prior to the event date.

II. PRICING: Pricing information is found in Attachment A.

III. CONTRACT ADMINISTRATION: The University's Executive Director of Events or designee, shall be identified by the University as the Contract Administrator and shall use all powers under the contract to enforce its faithfulness and performance in conjunction with the University's Procurement Services department. Although the contract will be administered by the Executive Director of Events, the University departments shall retain the authority to utilize this contract in accordance with their requirements.

The Contract Administrator shall determine the amount, quantity, acceptability, fitness of all aspects of the services and shall decide all other questions in connection with the services. The Contract Administrator shall not have authority to approve changes in the services which alter the concept or which call for an extension of the contract term. Any modifications made to the contract must be authorized by the University's Procurement Services Department through a written two-party modification to the contract.

IV. GENERAL TERMS AND CONDITIONS: Please refer to the link to follow regarding [Required General Terms and Conditions](#) of this Contract.

V. SPECIAL TERMS AND CONDITIONS:

- A. ACCESS TO WORK:** The University, the University's inspectors and other test personnel, and inspectors from Department of Labor and Industry, DEB, or other agencies as appropriate, shall have access to the work at all times. The Contractor shall provide proper facilities for access and inspection.

- B. ADDITIONAL GOODS AND SERVICES:** The University reserves the right to request from the contractor to provide additional Goods and/or Services under similar and market-based pricing, terms, and conditions, and to make modifications or enhancements to existing services. Additional Goods and Services may include other products, components, accessories, subsystems or related services that are newly introduced during the term of the Agreement. Newly introduced additional Services will be provided to the University at favored nations pricing, terms, and conditions.
- C. ADVERTISING TO THE GENERAL PUBLIC:** The Contractor shall not state in any of its advertising or product literature that the Commonwealth of Virginia or any agency or institution of the Commonwealth has purchased or uses its products or services.
- D. ANTITRUST:** The contractor conveys, sells, assigns, and transfers to the Commonwealth of Virginia all rights, title and interest in and to all causes of action it may now have or hereafter acquire under the antitrust laws of the United States and the Commonwealth of Virginia, relating to the particular goods or services purchased or acquired by the Commonwealth of Virginia under said contract.
- E. AUDIT:** The contractor shall retain all books, records, and other documents relative to this contract for five (5) years after final payment, or until audited by the Commonwealth of Virginia, whichever is sooner. The agency, its authorized agents, and/or state auditors shall have full access to and the right to examine any of said materials during said period.
- F. AVAILABILITY OF FUNDS:** It is understood and agreed between the parties herein that the agency shall be bound hereunder only to the extent of the funds available or which may hereafter become available for the purpose of this agreement.
- G. CANCELLATION OF CONTRACT:** The University reserves the right to cancel and terminate the contract, in part or in whole, without penalty, upon sixty (60) days' written notice to the Contractor. Any contract cancellation notice shall not relieve the Contractor of the obligation to deliver and/or perform all outstanding orders issued prior to the effective date of cancellation. The Contractor shall be entitled to receive full compensation for all University-accepted services performed and/or goods received prior to the effective date of contract termination. Contractor shall not be entitled to, and hereby waives claims for lost profits and all other damages and expenses.
- H. CHANGES TO THE CONTRACT:** Changes can be made to the contract by written mutual agreement to modify the scope of the contract. An increase or decrease in the price of the contract resulting from such modification shall be agreed to by the parties as a part of their written agreement to modify the scope of the contract.
- I. CONTROLLING VERSION:** The PDF version of the contract issued by University of Mary Washington Procurement Services is the mandatory controlling version of the document. Any modification and/or additions by the Contractor shall not modify the official version of the contract issued by UMW Procurement Services unless accepted in writing by the University.
- J. COMPLIANCE:** Failure to comply with any of the specifications contained in the scope of work provided herein may result in cancellation of contract.
- K. COOPERATIVE PROCUREMENT/ADDITIONAL USERS - USE OF AGREEMENT BY THIRD PARTIES:** It is the intent of this contract to allow for cooperative procurement. Accordingly, any public body (to include government/state agencies, political subdivisions, etc.), cooperative purchasing organizations, public or private health or educational institutions, or any University affiliated agency and/or corporation may access any resulting contract if authorized by the Contractor. Use of this Agreement does not preclude any participating entity from using other agreements or competitive processes.

Participation in this cooperative procurement is strictly voluntary. If authorized by the Contractor(s), the resultant contract(s) will be extended to the entities indicated above to purchase goods and services in accordance with contract terms. As a separate contractual relationship, the participating entity will place its own orders directly with the contractor and shall fully and independently administer its use of the contract to include contractual disputes, invoicing and payments without direct administration from the University. No modification of this contract or execution of a separate agreement is required to participate; however, the participating entity and the contractor may modify the terms and conditions of this contract to accommodate

specific governing laws, regulations, policies, and business goals required by the participating entity. Any such modification will apply solely between the participating entity and the Contractor.

The Contractor will notify the University in writing of any such entities accessing this Contract. The Contractor will provide semi-annual usage reports for all entities accessing the Contract. The University shall not be held liable for any costs or damages incurred by any other participating entity as a result of any authorization by the Contractor to extend the Contract. It is understood and agreed that the University is not responsible for the acts or omissions of any entity, and will not be considered in default of the Contract no matter the circumstances.

The Contractor is strongly encouraged to offer additional discounts to all contract participants as the result of increasing aggregated spend among all entities accessing the contract. A plan for extending deeper discounts among all contract participants will be requested during negotiations.

- L. CRIMINAL BACKGROUND CHECKS OF PERSONNEL ASSIGNED BY CONTRACTOR TO PERFORM WORK ON UMW PROPERTY:** The Contractor shall obtain criminal background checks on all of their contracted employees who will be assigned to perform services on UMW property. The results of the background checks will be directed solely to the Contractor. The Contractor bears the responsibility for confirming to the University Contract Administrator that the background checks have been completed prior to the work being performed by their employees or subcontractors. The Contractor shall only assign to work on University properties those individuals whom it deems qualified and permissible based on the results of completed background checks. Notwithstanding any other provision herein, and to ensure the safety of students, faculty, staff and facilities, UMW reserves the right to approve or disapprove any contract employee that will work on UMW property. Disapproval by UMW will solely apply to UMW property and should have no bearing on the Contractor's employment of an individual outside of UMW.
- M. DRUG FREE WORKPLACE:** During the performance of this contract, the Contractor agrees to (i) provide a drug-free workplace for the Contractor's employees; (ii) post in conspicuous places, available to employees and applicants for employment, a statement notifying employees that the unlawful manufacture, sale, distribution, dispensation, possession, or use of a controlled substance or marijuana is prohibited in the Contractor's workplace and specifying the actions that will be taken against employees for violations of such prohibition; (iii) state in all solicitations for advertisements for employees place by or on behalf of the Contractor that the Contractor maintains a drug-free workplace; and (iv) include the provisions of the foregoing clause in every subcontract or purchase order of over \$10,000, so that the provisions will be binding upon each subcontractor or Contractor.

For the purposes of this section, "drug-free workplace" means a site for the performance of work done in connection with a specific contract awarded to a Contractor, the employees of who are prohibited from engaging in the unlawful manufacture, sale, distribution, dispensation, possession or use of any controlled substance or marijuana during the performance of the contract.

- N. DEFAULT:** In case of failure to deliver goods or services in accordance with the contract terms and conditions, the Commonwealth, after due oral or written notice, may procure them from other sources and hold the contractor responsible for any resulting additional purchase and administrative costs. This remedy shall be in addition to any other remedies which the Commonwealth may have.
- O. DISCOUNTS:** a 10% courtesy discount is available for Lounge Furniture, Designer Bars, and Theme Décor. A 10% discount will also be offered on specialty items on a case-by-case basis.
- P. E-VERIFY PROGRAM:** Effective 12/1/2013, and pursuant to Code of Virginia, §2.2-4308.2., any employer with more than an average of 50 employees for the previous 12 months entering into a contract in excess of \$50,000 with any agency of the Commonwealth to perform work or provide services pursuant to such contract shall register and participate in the E-Verify program to verify information and work authorization of its newly hired employees performing work pursuant to such public contract. Any such employer who fails to comply with

these provisions shall be debarred from contracting with any agency of the Commonwealth for a period up to one year. Such debarment shall cease upon the employer's registration and participation in the E-Verify program. If requested, the employer shall present a copy of their Maintain Company page from E-Verify to prove that they are enrolled in E-Verify.

- Q. ENVIRONMENTAL LIABILITY:** Any costs or expenses associated with environmentally related violations of the law, the creation or maintenance of a nuisance, or releases of hazardous substances, including, but not limited to, the costs of any cleanup activities, removals, remediations, responses, damages, fines, administrative or civil penalties or charges imposed on the Contractor, whether because of actions or suits by any government or regulatory agency or by any private party, as a result of the storage, accumulation, or release of any hazardous substances, or any noncompliance with or failure to meet any federal, state or local standards, requirements, laws, statutes, regulations or the law of nuisance by Contractor (or by its agents, officers, employees, subcontractors consultants, sub-consultants, or any other persons, corporations or legal entities employed, utilized or retained by Contractor) in the performance of this Contract or related activities, shall be paid by Contractor. This paragraph shall survive the termination, cancellation or expiration of this Contract.
- R. EXCLUSIVITY:** The University reserves the right to procure goods or services covered under this contract from a third party when, in the University's sole discretion, it is deemed to be in the University's best interest.
- S. EXTRA CHARGES PROHIBITED:** The bid price shall be for the product and delivery, and shall include all applicable freight and transportation charges; extra charges will not be allowed.
- T. FINAL INSPECTION:** The contractor shall demonstrate to the authorized UMW representative that the work is fully operational and in compliance with contract specifications and code. Any deficiencies shall be promptly and permanently corrected by the contractor at the contractor's sole expense prior to final acceptance of the work.
- U. FISCAL YEAR PROCESSING:** The University of Mary Washington's fiscal year is July 1st through June 30th. Payment cannot be made for multiple fiscal years in advance of services.
- V. INDEMNIFICATION:** Contractor agrees to indemnify, defend and hold harmless the Commonwealth of Virginia, its officers, agents, and employees from any claims, damages and actions of any kind or nature, whether at law or in equity, arising from or caused by the use of any materials, goods, or equipment of any kind furnished by the Contractor/any services of any kind or nature furnished by the Contractor, provided that such liability is not attributable to the sole negligence of the using agency or to failure of the using agency to use the materials, goods, or equipment in the manner already and permanently described by the Contractor on the materials, good or equipment delivered.
- W. INDEPENDENT CONTRACTOR RELATIONSHIP:** In performing any and all of the services to be provided under this contract, the Contractor shall at all times and for all purposes be and remain an independent contractor. In no case and under no circumstances shall the Contractor or any of its employees, including but not limited to those of its employees actually performing any of the services, have authority to make any representations or commitments on behalf of the University or be considered the agent of the University for any purpose whatsoever. No persons engaged by the Contractor in connection with the provision of Services shall be considered employees of the University. As between the parties, the Contractor shall be responsible for hiring, supervising, training and instructing those individuals performing the services and shall pay any required state and federal taxes on behalf of such persons and provide them with any legally required employee benefits.
- X. INSPECTION:** All work and materials in each project shall be subject to final inspection by an authorized representative of the University. Any omission or failure on the part of such representative to disapprove or reject inferior or defective work or materials shall not be construed to be an acceptance of any such work or material. If any defective work or materials are found during inspection, the contractor shall remove or repair, at his own expense, such defective work or rejected material and shall correct and/or replace same without extra charge.

- Y. INSPECTION OF JOB SITE:** Contractor certifies that they have inspected the job site and are aware of the conditions under which the work must be accomplished. Claims, as a result of failure to inspect the job site, will not be considered by the University.
- Z. INSTALLATION:** All items must be assembled and set in place, ready for use. All crating and other debris must be removed from the premises.
- AA. INSURANCE:** By signing this contract, the Contractor certifies it will have the following insurance coverage at the time the contract is awarded and through the term of each contract renewal period. For construction contracts, if any subcontractors are involved, the subcontractor will have worker's compensation insurance in accordance with §§ 2.2-4332 and 65.2-800 et. Seq. of the Code of Virginia. The Contractor further certifies that the Contractor and any subcontractors will maintain these insurance coverages during the entire term of the contract and that all insurance coverage's will be provided by insurance companies authorized to sell insurance in Virginia by the Virginia State Corporation Commission.

Minimum Insurance Coverages and Limits Required for Most Contracts:

1. Workers' Compensation - Statutory requirements and benefits. Coverage is compulsory for employers of three or more employees, to include the employer. Contractors who fail to notify the Commonwealth of increases in the number of employees that change their workers' compensation requirements under the Code of Virginia during the course of the contract shall be in noncompliance with the contract.
 2. Employer's Liability - \$100,000.
 3. Commercial General Liability - \$1,000,000 per occurrence and \$2,000,000 in the aggregate. Commercial General Liability is to include bodily injury and property damage, personal injury and advertising injury, products and completed operations coverage. The Commonwealth of Virginia must be named as an additional insured and so endorsed on the policy.
 4. Automobile Liability - \$1,000,000 per occurrence (Only used if motor vehicle is to be used in the contract.)
- BB. KEYS:** If the Contractor is given keys for this project, it is the Contractor's responsibility to return the keys when the contract is terminated, as well as for the safekeeping of the keys during the contract period. The Contractor shall not loan or duplicate the keys. In the event the Contractor loses the keys, they will be charged for the replacement of the keys and any locks which are rekeyed or replaced.
- CC. LIQUIDATED DAMAGES, FURNISH AND INSTALL:** Work shall begin at the designated date and time requested by the contract administrator and all work shall be completed by the date and time stated on the purchase order. It is hereby understood and agreed by the contractor that time is of the essence in the delivery of supplies, services, materials, or equipment of the character and quality specified. In the event these specified supplies, services, materials, or equipment are not delivered by the date specified, the contractor will be responsible for re- procurement costs including, but not limited to, contracting with a new vendor to complete the necessary services; except that if the delivery be delayed by act, negligence or default on the part of the Commonwealth, public enemy, war, embargo, fire, or explosion not caused by the negligence or intentional act of the contractor or his supplier(s), or by riot, sabotage, or labor trouble that results from cause or causes entirely beyond the control or fault of the contractor or his supplier(s), a reasonable extension of time as the procuring public body deems appropriate may be granted. Upon receipt of a written request and justification for an extension from the contractor, the purchasing office may extend the time for

performance of the contract or delivery of goods herein specified at the purchasing office's sole discretion for good cause shown.

DD. MISS UTILITIES: As required, it shall be the Contractor's responsibility to contact Miss Utilities a minimum of forty-eight (48) hours prior to installation to have all existing underground utilities located, and shall be responsible for any damage to the underground utilities during the performance of this contract.

EE. OPERATING VEHICLES ON UMW CAMPUS: Operating Contractor vehicles on sidewalks, plazas, grass, flower beds, walkways, fountains, and University seal is prohibited. The safety of our students, faculty and staff is of paramount importance to us. Accordingly, violators may be charged.

FF. ORDERING PROCEDURES: The awardee of a contract under this solicitation shall be issued one (1) master contract, which will be valid for the term of the contract. Individual purchase orders will be issued on a per occurrence basis when goods are required. Each purchase order will reference the particular goods to be provided and the master contract number.

GG. PERMITS:

1. The University will be responsible to obtain all necessary permits for work directed under this contract.
2. The Contractor shall comply with all applicable federal, state, and local laws, codes, and regulations in connection with the accomplishment of work under this contract. The Contractor shall be responsible for all damages to persons and/or property that occur as a result of his fault or negligence. He shall take proper safety and health precautions to protect the work, the workers, the public and the property.

HH. PRICE ESCALATION/DE-ESCALATION:

1. Price adjustments may be permitted for changes in the contractor's cost of materials and are only authorized at time of renewal (exercise of option periods) and only if formally documented in a corresponding contract modification. However, "across the board" price decreases are subject to implementation at any time and shall be immediately conveyed to the University.
2. Contractor shall give not less than ninety (90) days advance notice of any price increase to the Procurement office. Any approved price changes will be effective only at the beginning of the term of the next option period. The contractor shall document the amount and proposed effective date of any general change in the price of materials. Documentation shall be supplied with the contractor's request for increase which will:
 - I. Verify that the requested price increase is general in scope and not applicable just to the University
 - II. Verify the amount or percentage of increase which is being passed on to the contractor by the contractor's suppliers.
3. The Procurement office will notify the using agencies and contractor in writing of the effective date of any increase which it approves. However, the contractor shall fill all purchase orders received prior to the effective date of the price adjustment at the old contract prices. The contractor is further advised that decreases which affect the cost of materials are required to be communicated immediately to the Procurement office.

II. RECYCLING POLICY: It shall be the policy of the University of Mary Washington to support and encourage conservation and recycling efforts by vendors, students, faculty and staff.

JJ. RENEWAL OF CONTRACT: This contract may be renewed by the Commonwealth for five (5) successive periods, or as negotiated, under the terms and conditions of the original contract except stated in 1. and 2. below. Price increases may be negotiated only at the time of renewal. Written notice of the Commonwealth's intention to renew shall be given approximately 90 days prior to the expiration date of each contract period.

1. If the University elects to exercise the option to renew the contract for an additional one- year period, the contract price(s) for the additional one year shall not exceed the contract price(s) of the original contract increased/decreased by more than the percentage increase/decrease of all the services

category of the CPI-U section of the Consumer Price Index of the United States Bureau of Labor Statistics for the latest twelve months for which statistics are available.

2. If during any subsequent renewal periods, the Commonwealth elects to exercise the option to renew the contract, the contract price(s) for the subsequent renewal period shall not exceed the contract price(s) of the previous renewal period increased/decreased by more than the percentage increase/decrease of the all services category of the CPI-W section of the Consumer Price Index of the United States Bureau of Labor Statistics for the latest twelve months for which statistics are available.

KK. SMALL BUSINESS SUBCONTRACTING AND EVIDENCE OF COMPLIANCE: It is the goal of the Commonwealth that 42% of its purchases are made from small businesses. This includes discretionary spending in prime contracts and subcontracts. All potential bidders/offerors are required to submit a Small Business Subcontracting Plan. Unless the bidder/offeror is registered as a Virginia Department of Small Business and Supplier Diversity (DSBSD)-certified small business and where it is practicable for any portion of the awarded contract to be subcontracted to other suppliers, the contractor is encouraged to offer such subcontracting opportunities to DSBSD-certified small businesses. This shall not exclude DSBSD-certified women-owned and minority-owned businesses when they have received DSBSD small business certification. No bidder/offeror or subcontractor shall be considered a Small Business, a Women- Owned Business or a Minority-Owned Business unless certified as such by the DSBSD by the due date for receipt of bids or proposals. If small business subcontractors are used, the prime contractor agrees to report the use of small business subcontractors by providing the purchasing office at a minimum the following information: name of small business with the DSBSD certification number, phone number, total dollar amount subcontracted, category type (small, women-owned, or minority-owned), and type of product/service provided.

- i. Each prime contractor who wins an award in which provision of a small business subcontracting plan is a condition of the award, shall deliver to the contracting agency or institution on a monthly or quarterly basis, evidence of compliance (subject only to insubstantial shortfalls and to shortfalls arising from subcontractor default) with the small business subcontracting plan. When such business has been subcontracted to these firms and upon completion of the contract, the contractor agrees to furnish the purchasing office at a minimum the following information:
 - I. Name of firm with the DSBSD certification number
 - II. Phone number
 - III. Total dollar amount subcontracted
 - IV. Category type (small, women-owned, or minority-owned)
 - V. Type of product or service provided

Payment(s) may be withheld until compliance with the plan is received and confirmed by the agency or institution. The agency or institution reserves the right to pursue other appropriate remedies to include, but not be limited to, termination for default.

2. Each prime contractor who wins an award valued over \$200,000 shall deliver to the contracting agency or institution on a monthly or quarterly basis, information on use of subcontractors that are not DSBSD-certified small businesses. When such business has been subcontracted to these firms and upon completion of the contract, the contractor agrees to furnish the purchasing office at a minimum the following information: name of firm, phone number, total dollar amount subcontracted, and type of product or service provided.

LL. STANDARDS OF CONDUCT: The work site will be occupied by students and University Personnel during the times work is performed. Contractor and Contractor's personnel shall exercise a particularly high level of discipline, safety and cooperation at all times while on the job site. The Contractor shall be responsible for

controlling employee conduct, for assuring that employees are not boisterous or rude, and assuring that they are not engaging in any destructive or criminal activity. The Contractor is also responsible for ensuring that its employees do not disturb papers on desks, or open drawers, cabinets, or briefcases, or use State phones, and the like, except as authorized.

UMW, an agency of the Commonwealth of Virginia, strictly forbids harassment of any employee, applicant for employment, vendor, contractor or volunteer in the workplace*, or on the basis of an individual's race, sex, color, national origin, religion, sexual orientation, age, veteran status, political affiliation or disability. The Commonwealth will not tolerate any form of retaliation directed against an employee or third party* who either complains about harassment or who participates in any investigation concerning harassment.

The Commonwealth expressly prohibits workplace violence*. Prohibited conduct includes, but is not limited to: Injuring another person physically; Engaging in behavior that creates a reasonable fear of injury to another person; Engaging in behavior that subjects another individual to extreme emotional distress; Possessing, brandishing, or using a weapon that is not required by the individual's position while on state premises or engaged in state business; Intentionally damaging property; Threatening to injure an individual or to damage property; Committing injurious acts motivated by, or related to, domestic violence or sexual harassment; and Retaliating against any employee who, in good faith, reports a violation of this policy.

Violations of the above standards of conduct may result in requests for apparent offenders to temporarily or permanently leave the workplace.

MM. SUBCONTRACTS: No portion of the work shall be subcontracted without prior written consent of the purchasing agency. In the event that the contractor desires to subcontract some part of the work specified herein, the contractor shall furnish the purchasing agency the names, qualifications and experience of their proposed subcontractors. The contractor shall, however, remain fully liable and responsible for work to be done by its subcontractor(s) and shall assure compliance with all requirements of the contract.

The contractor shall be responsible for completely supervising and directing the work done under this contract by subcontractors that may be utilized in support of the contract, using the contractor's best skill and attention. Subcontractors performing work under this contract shall be accountable to the prime contractor.

NN. SUBMISSION OF INVOICES: All invoices shall be submitted within thirty (30) days of contract term expiration for the initial contract period as well as for each subsequent contract renewal period. Any invoices submitted after the thirty (30) day period will not be processed for payment.

OO. USE OF PREMISES AND REMOVAL OF DEBRIS: The contractor shall:

1. Perform his contract in such a manner as not to interrupt or interfere with the operation of any existing activity on the premises or with the work of any contractor;
2. Store his apparatus, materials, supplies, and equipment in such orderly fashion at the site of the work as will not unduly interfere with the progress of his work or the work of any other contractor; and
3. Place upon the work or any part thereof only such loads as are consistent with the safety of that portion of the work.
4. To clean up frequently all refuse, rubbish, scrap materials, and debris caused by his operations, to the end at all times the site of the work shall present a neat, orderly and workmanlike appearance.
5. Vehicle parking shall be permitted in designated areas. Contractor shall obtain approval from the Contract Administrator for parking in other areas.

PP. WARRANTY OF MATERIALS AND WORKMANSHIP: The Contractor warrants that, unless otherwise specified, all materials and equipment incorporated in the work under the contract be new, in first class condition, and in accordance with the contract documents. The Contractor further warrants that all workmanship shall be of the highest quality and in accordance with contract documents and shall be performed by persons qualified at their respective trades. Work not conforming to these warranties shall be considered defective. This warranty of materials and workmanship is separate and independent from and in addition to any of the Contractor's other guarantees or obligations in this contract.

QQ. WORK SITE DAMAGES: Any damage to existing utilities, equipment or furnished surfaces resulting from the performance of this contract shall be repaired to the Commonwealth's satisfaction at the contractor's expense.

RR. WORK SITE USE: The Contractor expressly undertakes, either directly or through its Subcontractor(s):

1. To comply with the regulations governing the operation of premises and to perform its contract in such a manner as not to interrupt or interfere with the operation of any existing activity on the premises or at the location of the work.
2. To store all apparatus, materials, supplies and equipment in such orderly fashion at the site of the work as will not unduly interfere with the progress of the work or the University's use of the facilities.
3. To place upon the work or any part thereof only such loads as are consistent with the safety of that portion of the work.
4. To clean up frequently all refuse, rubbish, scrap materials, and debris caused by his operation, to the end that all times the site of the work shall present a neat, orderly and workmanlike appearance.

SS. CONFLICT OF TERMS: In the event of any inconsistency or conflict between the provisions of this Agreement and any other related rental agreements, policies, or documents referenced herein, the terms of this Agreement shall prevail.

VI. METHOD OF PAYMENT/PAYMENT TERMS: The contractor shall be paid using one of the following methods for all University initiated procurements:

1. University Charge Card: At the time of verified receipt of goods or services, if the Contractor accepts credit cards in payment, the University will authorize payment by UMW charge card, currently through the Bank of America Visa. Any "Check-out fees" imposed by the contractor must be disclosed prior to the purchase. No check-out fee or surcharge may be greater than 3% of the total sale, effective 4/15/2023. The University expects that these costs, as well as all contractor business expenses will be built into the contractor's quoted price.
2. Virtual Payables through Bank of America: All payments under Virtual Payables will have a net 16 payment term.
3. Check or ACH: Payment will be made 30 days after satisfactory performance of the contract in all provisions thereof and upon receipt of a properly completed invoice, whichever is later; in accordance with Chapter 43, VPPA, Article 4, Code of Virginia.

To be considered eligible for payment, all physical invoices must be received at the address below and should reference the eVA purchase order and UMW contract numbers as applicable. All electronic invoices must be sent to invoices@mail.umw.edu. *The University will not be responsible for late payment or nonpayment of invoices not received directly by Accounts Payable at this email address or at the mailing address indicated (below).*

UNIVERSITY OF MARY WASHINGTON
Attn: ACCOUNTS PAYABLE
1301 COLLEGE AVENUE
FREDERICKSBURG, VA 22401

Note: This public body does not discriminate against faith-based organizations in accordance with the *Governing Rules §36* or against a bidder or offeror because of race, religion, color, sex, national origin, age, disability, or any basis prohibited by state law relating to discrimination in employment.

In witness, whereof, the parties have caused this Contract to be duly executed intending to be bound thereby.

AMPA ENTERTAINMENT, INC DBA AMPA EVENTS

UNIVERSITY OF MARY WASHINGTON

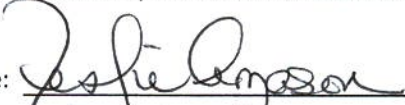
Signature: 
Printed Name: Leslie Amason
Title: Director of Sales
Date: 9/23/25
Phone: 804-358-5451
Email: lesliea@ampaevents.com

Signature: _____
Printed Name: Melva Kishpaugh
Title: Director, Procurement Services
Date: September 24, 2025

ATTACHMENT A
PRICING

The Contractor agrees to provide the services in compliance with the scope of work for each specific line item/services at a firm fixed price for the period of this agreement as follows.

In any instance where the contractor cannot provide the required services within an acceptable timeframe, the University reserves the right to purchase these services on the open market.

The quantities are estimated quantities used for evaluation purposes only. The University reserves the right to purchase those services actually needed and in quantities as required by the University regardless of whether such total quantities are more or less than those shown.

Item No	Description	Daily Rental	Quantity	Unit	Total
TENTS and Canopies (Provide, Install, and Remove)	To include poles and concrete anchors, courtyard tents (all require concrete anchors)				
1	Tents, 10' x 10', Standard Tent	\$ 145		Each	\$
2	Tents, 10' x 10', High Peaked	\$		Each	\$
3	Tents, 15' x 15'	\$ 330			
4	Tents, 15' x 30'	\$ 465		Each	\$
5	Tents, 20' x 20'	\$ 425		Each	\$
6	Tents, 30' x 30'	\$ 850		Each	\$
7	Tents, 30' x 40'	\$ 995		Each	\$
8	Tents, 30' x 45'	\$ 920		Each	\$
9	Tents, 30' x 50'	\$		Each	\$
10	Tents, 30' x 60'	\$ 1250		Each	\$
11	Tents, 30' x 75'	\$		Each	\$
12	Tents, 40' x 80'	\$ 2100		Each	\$
13	Tents, 60' x 100'	\$ 3800		Each	\$
14	Tents, 80' x 100'	\$		Each	\$
15	Tents, 80' x 210"	\$		Each	\$
16	Clear Top Tent, 30' x 30'	\$		Each	\$
17	Clear Top Tent, 30' x 40'	\$		Each	\$
18	Clear Top Tent, 30' x 45'	\$		Each	\$
19	Clear Top Tent, 30' x 50'	\$		Each	\$
20	Clear Top Tent, 30' x 60'	\$		Each	\$
21	Clear Top Tent, 30' x 30'	\$		Each	\$
22	Clear Top Tent, 30' x 75'	\$		Each	\$
23	Clear Top Tent, 30' x 90'	\$		Each	\$
24	Clear Top Tent, 40' x 45'	\$		Each	\$
25	Clear Top Tent, 40' x 50'	\$		Each	\$
26	Clear Top Tent, 40' x 60'	\$ 2992.50		Each	\$
27	Clear Top Tent, 40' x 80'	\$ 3375		Each	\$
28	Clear Top Tent, 40' x 100'	\$ 3765		Each	\$
29	Clear Peak Tent, 10' x 10'	\$		Each	\$
30	Clear Peak Tent, 10' x 20'	\$		Each	\$
31	Clear Peak Tent, 15' x 15'	\$		Each	\$
32	Clear Peak Tent, 20' x 20'	\$		Each	\$

33	Clear Peak Tent, 20' x 30'	\$		Each	\$
34	Clear Peak Tent, 20' x 40'	\$		Each	\$
35	Sail Cloth Tent, 45' x 44'	\$		Each	\$
36	Sail Cloth Tent, 45' x 64'	\$		Each	\$
37	Sail Cloth Tent, 45' x 84'	\$		Each	\$
38	Sail Cloth Tent, 45' x 104'	\$		Each	\$
TENT Accessories (Provide, Install, and Remove)					
39	Concrete Anchors	\$ 12.00		Each	\$
40	Concrete Covers	\$		Each	\$
41	Tent Pole Covers	\$ 20.00		Each	\$
42	Tent Liner for Each Size Tent	\$		Each	\$
43	Tent Lights, Bistro – Black and White	\$		Each	\$
44	Tent Lights, Lanterns, Japanese 12", 16", 20" and 24"	\$ 15-20.00		Each	\$
45	Tent Fan	\$ 110		Each	\$
46	Tent Fan - 12"	\$		Each	\$
47	Tent Fan – 18"	\$		Each	\$
48	Drum Fan, 24"	\$		Each	\$
49	Tent Gutter	\$ 15.00		Each	\$
TABLES (Rental, Set-up, Breakdown)					
50	Banquet Rectangular 4' x 30"	\$ 6.90		Each	\$
51	Banquet Rectangular 6' x 30"	\$ 8.10		Each	\$
52	Banquet Rectangular 8' x 30"	\$ 8.60		Each	\$
53	Banquet Rectangular 6' x 18"	\$		Each	\$
54	Banquet Rectangular 8' x 18"	\$		Each	\$
55	Banquet Rectangular 8' x 30" Children's Table	\$		Each	\$
56	Banquet Round 3'	\$ 7.80		Each	\$
57	Banquet Round 4'	\$ 12.50		Each	\$
58	Banquet Round 5'	\$ 15.50		Each	\$
59	Banquet Round 6'	\$ 16.00		Each	\$
60	Cocktail Rounds Tall and Standard Heights 24"	\$ 10.75		Each	\$
61	Cocktail Rounds Tall and Standard Heights 30"	\$ 11.85		Each	\$
62	Square 2', Standard and High Top	\$ 25.00		Each	\$
63	Square 4', Standard	\$ 35.00		Each	\$

64	Square 5', Standard	\$ 45.00		Each	\$
65	Serpentine 8'	\$ 11.00		Each	\$
66	Timberwood Farm Table, 4' x 8'	\$ 145.00		Each	\$
67	Timberwood Benches for Farm Table	\$		Each	\$
68	King Table, 4' x 8' Rectangular Table	\$		Each	\$
CHAIRS (Rental, Set-up, Breakdown)		\$		Each	\$
69	Padded Garden, White, Black and Natural	\$ 4.00		Each	\$
70	Folding Black, White, and Tan	\$ 1.50		Each	\$
71	Chivari Barstool, Black and Natural, mahogany,	\$ 17.00		Each	\$
72	Chivari Black, Gold, Silver, Mahogany, and White	\$ 17.00		Each	\$
73	Set Up/Knock Down of Chairs	\$		Each	\$
STAGE SECTIONS, 4' X 8' (PROVIDE, INSTALL, AND REMOVE)					
74	Stage, 12" High	\$ 50.00		Each	\$
75	Stage, 32" High	\$ 75.00		Each	\$
STAGE EQUIPMENT (PROVIDE, INSTALL AND REMOVE)					
76	Staging (Risers 4 x 4)	\$ 35/45.00		Each	\$
77	Staging Steps	\$ 162.50		Each	\$
78	Black Astroturf Covering for Stage	\$.60 sq ft		Each	\$
79	4' Guard Rails for Staging	\$ 25.00		Each	\$
80	ADA Access Ramps by the Foot	\$ 125.00		Each	\$
STAIRS (PROVIDE, INSTALL AND REMOVE)					
81	Stairs, 12" High	\$ 50.00		Each	\$
82	Stairs, 32" High	\$ 75.00		Each	\$
PIPES AND DRAPES (RENTAL ONLY)					

83	10' High Black, Navy Blue and Royal Blue, White	\$ 70.00		Each	\$
84	12' High Black, Navy Blue and Royal Blue, White	\$ 80.00		Each	\$
85	20' High Black, Navy Blue and Royal Blue, White	\$ 125.00		Each	\$
STANCHIONS (RENTAL ONLY)					
86	36" High, without Rope	\$ 15/25.00		Each	\$
87	White Plastic with White Plastic Chain	\$		Each	\$
STANCHIONS CHROME PORTA POST					
88	6' Section Red and Black Velour Rope	\$ 15.00		Each	\$
89	8' Section Red and Black Velour Rope	\$		Each	\$
ARCHES (PROVIDE, INSTALL AND REMOVE)					
90	Wood	\$ 97.50		Each	\$
COLUMN (PROVIDE, INSTALL AND REMOVE)					
91	33"	\$ 45.00		Each	\$
92	46"	\$ 45.00		Each	\$
93	56"	\$ 25.00		Each	\$
94	76"	\$ 65.00		Each	\$
95	Stage Façade, 3' x 4'	\$		Each	\$
96	Bar Top for Rectangular Table and Skirting, 6'	\$		Each	\$
SCREEN (PROVIDE, INSTALL AND REMOVE)					
97	6 Panel Bi-Fold Screen, White	\$		Each	\$
LOUNGE FURNITURE (PROVIDE, INSTALL AND REMOVE)					
98	Sectional Full Sofa	\$ 292.50		Each	\$
99	Sectional Love Seat	\$ 180.00		Each	\$
100	Sectional Arm Chair	\$ 210.00		Each	\$

101	Sectional Ottoman	\$		Each	\$
FLOORING (PROVIDE, INSTALL AND REMOVE)					
102	Deck Flooring	\$ 1.55 sq ft		Each	\$
103	Dance Floor	\$ 1.75 sq ft		Each	\$
104	25' Red Carpet	\$ 50.00		Each	\$
105	50' Red Carpet	\$ 75.00		Each	\$
MISCELLANEOUS (PROVIDE, INSTALL AND REMOVE)					
106	6' Bar Tops for Rectangular Tables	\$		Each	\$
107	Portable Bar	\$ 150.00		Each	\$
BAR					
108	Portable Acrylic Bar	\$ 575.00		Each	\$
COMMENCEMENT STAGING	See requirements for staging along with diagrams (Reference Attachment 7 to this RFP)	\$		Each	\$
DELIVERY		(Per Order)	(Flat Rate)		
109	Delivery and Pickup Charge, Flat Rate, for Chairs, Tables, Pipe and Drapes, Stanchions, and other items as Required.	\$ 575.00	\$	Events	\$
TOTAL NET PRICING:					
110	Informational Pricing: The Contractor offers to the University the following discount from the contractor's standard published list price in effect at the time of the rental for all items not listed above % - Listed Price				

Commencement Staging price per Attachment 7 of the RFP is \$15,000. The price includes the deck, two stairs, rails, and carpet, and an estimated 366 white folding chairs as needed based on the RFP floor plans.

University of Mary Washington

Request for Proposal

RFP# UCPUMW 25-1937

Special Event Equipment Rental

June 3, 2025



<https://vascupp.org>

A VASCUPP™ Member Institution
Issued by Procurement Services
Fredericksburg, Virginia

SEALED REQUEST FOR PROPOSAL (RFP)

ISSUE DATE: June 3, 2025

RFP NUMBER & TITLE: UCPUMW 25-1937, Special Event Equipment Rental

PROPOSAL DUE DATE & TIME: July 3, 2025, 2:00 p.m.
NOTE: Proposals received after the due date and time cannot be accepted.

PROPOSAL DELIVERY: **Electronic file upload to eVA only**

WORK LOCATION: All Campuses Fredericksburg Stafford Dahlgren

COMMODITY CODE(S): 97741, 96234, 98172, 98143, 98136, 97732, 96260, 97735

PRE-PROPOSAL CONFERENCE: Optional Mandatory N/A **DATE & TIME: July 10, 2025 at 10:00 a.m.**

PRE-PROPOSAL LOCATION: Eagle Village Executive Offices, Suite 480
1125 Emancipation Hwy., Fredericksburg, VA 22401

CONTRACT OFFICER: Kenneth Manahan **EMAIL:** kmanaha2@umw.edu

PERIOD OF CONTRACT: August 1, 2025 through July 31, 2026 with five, one-year renewal options that if exercised will extend the term of the contract through July 31, 2031.

In compliance with this Sealed Request for Proposal (RFP) and to all the conditions imposed therein, and hereby incorporated by reference, the undersigned firm offers and agrees to furnish the goods/services in accordance with attached signed proposal or as mutually agreed upon by subsequent negotiation. The undersigned firm hereby certifies that all information provided in response to this RFP is true, correct and complete.

By signing this proposal, you are certifying that you are an authorized representative of the offering firm and that the firm's principals or legal counsel have reviewed the Request for Proposal General Terms and Conditions and any Special Terms and Conditions. Any exceptions to the General or Special Terms and Conditions must be clearly identified in your proposal. No exceptions can be made to those General or Special Terms and Conditions that are mandated by law. If no exceptions are identified in your proposal, it is understood that the provisions will become a part of any final agreement.

THIS FORM MUST BE COMPLETED AND RETURNED WITH PROPOSAL

Name of Offering Firm: _____

Address of Offering Firm: _____

[DSBSD](#) Certification No.: _____ Expiration Date: _____

eVA ID: _____ Tax ID: _____

Email: _____ Telephone: _____

Website: _____ Fax: _____

Submitted By (Print Name & Title): _____

Signature (In Ink): _____ Date: _____

- I. QUESTIONS/INQUIRIES:** All inquiries for information should be directed via email to the contract officer listed above, referencing the RFP by title and number. No questions will be accepted after 2:00 p.m., June 12, 2025.
- II. PRE-PROPOSAL CONFERENCE:** An optional pre-proposal conference will be held on July 10, 2025 at 10:00 a.m. in the Eagle Village Executive Offices, Suite 480, 1125 Emancipation Hwy., Fredericksburg, VA 22401. See Pre-Proposal Conference clause in the Special Terms and Conditions section of this RFP.
- Those planning to attend shall notify the Contract Officer, via email, no later than 3 days prior to the conference date.
 - No attendee will be permitted access to the conference after 10:00 a.m.
 - Bring a copy of the RFP with you to the conference.
 - Parking is available to visitors in designated locations which can be found on the UMW campus map here: <http://www.umw.edu/visitors/>
- III. PROPOSAL RECEIPT REQUIREMENTS:** Sealed Proposals for furnishing the services described herein shall be submitted electronically via upload to the RFP 's eVA site, with eh option to submit a hard copy.
- A. Electronic Online Response via eVA:**
- The Offeror must submit their proposal via the electronic online response function within the solicitation posting on the eVA Virginia Business Opportunities (VBO).
**If you run into issues submitting your proposal electronically through eVA, please contact eVA Customer Care at 1-866-289-7367.*
- B.** The issuance of this solicitation does not guarantee an award of a contract.
- C.** UMW requires the inclusion of a clearly marked redacted proposal if any portion of the Offeror's proposal contains proprietary information. The redacted file shall also be uploaded to the eVA site with the file name including the word "Redated Version".
- IV. ADDENDA:** Any changes resulting from the University's requirements will be issued in an addendum and will be posted on the eVA website: <http://www.eva.virginia.gov>. It is the sole responsibility of the Offeror to check for all changes to the RFP prior to submission.
- V. INCLEMENT WEATHER/SUSPENDED SCHEDULE:** Proposal receipt deadline scheduled during a period of suspended state business operations, including school closing due to inclement weather, will be rescheduled for processing at the same time on the next regular business day. It is your responsibility to check UMW's website or call for closing information: www.umw.edu or (540) 654-2424.
- VI. PUBLIC RELEASE OF INFORMATION:** UMW utilizes a Public Contracts Portal (Cobblestone) <https://umw.cobblestonesystems.com/public/> for posting of procurement documents, including winning proposals. Further, if the resulting contract includes cooperative language, the VASCUPP public portal <https://vascupp.org/contracts> will be used to house relevant procurement documents, including winning offeror's proposal.

TABLE OF CONTENTS

I.	PURPOSE	5
II.	ORGANIZATIONAL OVERVIEW	5
III.	BACKGROUND	5
IV.	CONTRACT PARTICIPATION (COOPERATIVE CONTRACT)	6
V.	SMALL, WOMAN-OWNED, AND MINORITY-OWNED (SWAM) PARTICIPATION	6
VI.	PROPOSAL PREPARATION AND SUBMISSION REQUIREMENTS	6
VII.	STATEMENT OF NEEDS	10
VIII.	CONTRACT ADMINISTRATION	14
IX.	EVALUATION AND AWARD CRITERIA	14
X.	GENERAL TERMS AND CONDITIONS	14
XI.	SPECIAL TERMS AND CONDITIONS	14
XII.	SUPPLIER ONBOARDING and METHOD OF PAYMENT	25
 ATTACHMENTS		
1.	Single, Emergency and Administrative Point of Contact Identification Sheet (Must be submitted with proposal)	27
2.	Contractor Data Sheet (Must be submitted with proposal)	29
3.	Pricing Schedule (Must be submitted with proposal)	30
4.	Small Business Subcontracting Plan (Must be submitted with proposal)	35
5.	Subcontracting Spend Reporting	37
6.	Proposal Checklist	38
7.	Staging Diagram	39

Note: This public body does not discriminate against faith-based organizations in accordance with §36 of the Governing Rules or against a bidder or offeror because of race, religion, color, sex, national origin, age, disability, or any other basis prohibited by state law relating to discrimination in employment.

- I. **PURPOSE:** The intent and purpose of this Request for Proposal (RFP) is to solicit proposals from qualified sources, with the Offeror's Service Center located within a seventy-five (75) mile radius of the university of Mary Washington Fredericksburg, VA campus, to establish one or more contracts through competitive negotiations with qualified contractors. The awarded contract(s) will provide furniture, equipment (such as heaters, generators, fans, etc.), portable shelters (tents, arches, etc.), temporary platforms (staging), sundry rentals (linens, props, etc.), and other necessary items for various events, as outlined herein, at the University of Mary Washington ("UMW" or "the University"), an agency of the Commonwealth of Virginia.

These rented items will be required for UMW's annual key events, including but not limited to Commencement, Family Weekend, the Chappell Great Lives Series, Alumni Reunions, the Multicultural Fair, and Orientation. Additionally, rented items will be needed for Presidential Events, public and private events such as weddings, and any other gatherings requiring similar equipment, structures, furniture, sundry rentals, and services. Events covered by the awarded contract(s) may be held indoors or outdoors.

The resulting contract will be awarded to those qualified contractors who present the best overall value to UMW in terms of: 1) types and availability of required equipment, structures, supplies, and services; 2) available capacity to meet UMW scheduling requirements for annual key events; 3) a demonstrated past performance in the industry, and 4) presenting the best overall pricing options considering rental prices, discounts, rebates, sponsorships and any associated delivery and add-on pricing.

The University makes no guaranteed minimum amount of purchase or future business with the award of a contract.

It is intended for the resulting contract to include cooperative language for the benefit of all public bodies and other entities referenced herein.

- II. **ORGANIZATION OVERVIEW:** Founded in 1908, the University of Mary Washington, is a premier, selective, coeducational, public liberal arts institution that offers rigorous academics in small classroom settings, innovative master teachers, a supportive campus community that values honor and integrity, and a civically, socially, and intellectually engaged community. Located within the Commonwealth of Virginia in Fredericksburg, UMW resides within an hour's drive of both the nation's Capital of Washington, D.C. and the State Capital of Richmond, offering students unique opportunities for internships, research excursions, and recreation. The University currently consists of three colleges for Arts and Sciences, Business, and Education, and two additional campuses: one in Stafford, VA and the other in Dahlgren, VA. For more information about the University of Mary Washington: <http://www.umw.edu/about/>.
- III. **BACKGROUND:** The UMW Office of Events and Conferencing promotes the brand of UMW and extends its overall mission of service, by treating various constituencies and individuals – both public and university-related – as clients, who are entitled to the office's resources and professionalism in connection with planning and pursuing presentations that require one-stop management, facilitation, and completion. The Office of Events plans and coordinates logistics for Presidential (inaugurations and presidential addresses) and Major Institutional Events (Family Weekend, the Chappell Great Lives Series, and Commencement). In addition, the Office of Events provides consultation services for other UMW and Community Events (Multi-Cultural Fairs, Alumni

Weekend, to name a few), including internal and external groups planning to host an event at the University.

UMW properties include the Fredericksburg Campus (William Anderson Center, Dodd Auditorium, University Campus Center, Tennis Center, Academic Buildings, and Athletic Fields); the Jepson Alumni Executive Center and Kalnen Inn; the Stafford Campus; the Dahlgren Campus; University Galleries (Ridderhof Martin Gallery, Gari Melchers Home and Studio at Belmont, and James Monroe Museum).

IV. CONTRACT PARTICIPATION – COOPERATIVE PURCHASING/USE OF AGREEMENT BY THIRD PARTIES:

- A. Under the authority of §6 of the Rules Governing Procurement of Goods, Services, Insurance and Construction by a Public Institution of Higher Education of the Commonwealth of Virginia (copy available at [https://vascupp.org/sites/vascupp/files/2022-08/Governing%20Rules with foreword final August%202022.pdf](https://vascupp.org/sites/vascupp/files/2022-08/Governing%20Rules%20with%20foreword%20final%20August%202022.pdf)), it is the intent of this solicitation and resulting contract(s) to allow for cooperative procurement. Accordingly, any public body (to include government/state agencies, political subdivisions, etc.), cooperative purchasing organizations, public or private health or educational institutions or any University related foundation and affiliated corporations may access any resulting contract if authorized by the contractor.
- B. Participation in this cooperative procurement is strictly voluntary. If authorized by the Contractor(s), the resultant contract(s) may be extended to the entities indicated above to purchase goods and services in accordance with the contract terms. As a separate contractual relationship, the participating entity will place its own orders directly with the Contractor(s) and shall fully and independently administer its use of the contract(s) to include contractual disputes, invoicing and payments without direct administration from UMW. No modification of this contract or execution of a separate agreement is required to participate; however, the participating entity and the Contractor may modify the terms and conditions of this contract to accommodate specific governing laws, regulations, policies, and business goals required by the participating entity. Any such modification will apply solely between the participating entity and the Contractor.
- C. UMW shall not be held liable for any costs or damages incurred by any other participating entity as a result of any authorization by the Contractor to extend the contract. It is understood and agreed that UMW is not responsible for the acts or omissions of any entity and will not be considered in default of the contract no matter the circumstances. Use of this contract(s) does not preclude any participating entity from using other contracts or competitive processes as needed.

V. SMALL, WOMAN-OWNED AND MINORITY-OWNED (SWAM) PARTICIPATION:

It is the policy of the Commonwealth of Virginia to contribute to establishment, preservation, and strengthening of small businesses and businesses owned by women and minorities and to encourage their participation in State procurement activities. The Commonwealth encourages contractors to provide for the participation of Small (includes Micro) and otherwise Diverse Businesses through partnerships, joint ventures, subcontracts, and other contractual opportunities.

VI. PROPOSAL PREPARATION AND SUBMISSION REQUIREMENTS:

A. GENERAL PROPOSAL PREPARATION AND SUBMISSION REQUIREMENTS:

1. Proposal Requirements - The University reserves the right to:
 - accept or reject any and all proposals, in whole or in part, received as a result of this RFP,
 - waive minor informalities,

- issue a lowered evaluation of the proposal for failure to submit all information requested,
- negotiate with any or all responsible vendors in any manner necessary to serve the best interests of the University, or accept the best proposal as submitted, without negotiation.

Any proposal submitted without a signature binding the Offeror to the proposal will be considered non-responsive and may be rejected. *This Request for Proposal creates no obligation on the part of the University to award a contract or to compensate vendors for proposal preparation expenses.*

2. Protection of Trade Secrets/Proprietary Information: The Virginia Freedom of Information Act “FOIA” requires release of any procurement documents that are not appropriately marked and protected through the Trade Secrets or Proprietary Information provisions outlined in the paragraphs below.

If the Offeror intends to protect any Trade Secrets or Proprietary Information, they must:

- invoke the protection of the Code of Virginia, § 2.2-4342F, **in writing**, stating the reasons why protection is necessary, and,
- submit, at the same time as the original proposal submission, a separate redacted version of the proposal which contains identical content but blacks out any protected information not appropriate for public release. *If a redacted proposal is not received at the same time as the original proposal, no part of the document may later be protected by the Offeror and restricted from public review.*

The designating of an entire proposal document, line-item prices and/or total proposal prices as proprietary or as a trade secret is not acceptable. If, after being given reasonable time, the Offeror refuses to withdraw the entire proposal designation as proprietary and/or confidential, the proposal will be rejected.

3. Oral Presentations: Offerors who submit a proposal in response to this RFP may be required to give an oral presentation of their proposal to the University. This will provide an opportunity for the Offeror to clarify or elaborate on the proposal. This is a fact-finding and explanation session only and does not include negotiation. *Oral presentations are an option of the university and may not be conducted. Therefore, proposals submitted in response to this RFP should not be submitted with the presumption that there will be opportunities to revise the proposal after submission.*

4. Number of Proposals Required:

- a. One (1) original electronic version of the proposal is required and, if required by the Offeror, one (1) separate electronic version clearly marked “Redacted Copy”. The file(s) must be uploaded to eVA.

5. Proposal Formatting and Content: Proposals should be as detailed as possible so that the University of Mary Washington may properly evaluate the Offeror’s capabilities to provide the required services, and shall be straight forward and concise.

6. Limited Contact: To ensure timely and adequate consideration of your proposal, Offerors are to limit all contact, whether verbal or written, pertaining to this RFP to the UMW Procurement Office Contract Officer indicated on the face of this document for the duration of this Procurement process. Failure to do so may jeopardize further consideration of an Offeror’s Proposal.

B. **SPECIFIC PROPOSAL PREPARATION AND SUBMISSION REQUIREMENTS:** Proposals should be as thorough and detailed as possible. Offerors are required to include all of the following items within their proposal. **For evaluation purposes, it is requested that the information be provided in the same order as they appear within this section.**

1. Complete and return SIGNED RFP cover page. Proposals shall be signed by an authorized representative of the Offeror.
2. Company Information:
 - a. Provide a brief description and history of the firm, including information detailing experiences and qualifications of the firm to provide this solution, such as number of years in business providing similar solutions to similar entities, preferably in higher education.
 - b. Identify the number and total value of sales your company has had (if any) during the last twelve months with each public Higher Education Institution within the Commonwealth of Virginia.
 - c. Identify the location of your business indicating it is within the required 75-mile radius of UMW.
 - d. Provide a certificate of insurance to substantiate the coverage is adequate to meet the University's insurance requirements as described within the Special Terms and Conditions (Section XII) contained herein.
3. Provide an understanding of the Section XII Special Terms & Conditions requirements for the following sections:
 - a. "Requirement for Criminal Background Check of Personnel Assigned by Contactor to Perform Work on UMW Property" (section XII, Q.)
 - b. Drug-Free Workplace" (Section XII, R.)
4. Include the following completed Attachments within the proposal:
 - a. Point of Contact Information, Attachment 1.
 - b. Contractor Data Sheet, Attachment 2.
 - c. Pricing Schedule, Attachment 3
 - d. Subcontracting Plan, Attachment, 4
5. Offeror's Qualifications, Experience and Past Performance:
 - a. Describe your understanding and any experience with temporary structure permits through the Commonwealth of Virginia, Bureau of Capital Outlay Management.
 - b. Identify your proposed single point of contact, emergency point of contact and business (invoicing) point of contact (reference Attachment 1) for all UMW special event rental services.
 - c. Provide three references for contracts with similar size, scope, capabilities. Include the contract number, the agency name, the point of contact (Contracts and/or actual Customer), phone number, and email address, along with date of service and value of the order (reference Attachment 2, Contractor Data Sheet).
 - d. Identify your direct experience and expertise in convention, event, or hospitality industry.
 - e. Describe ability to provide special event rental services for small or large, multi-location events. Be specific in detailing the event from beginning to end including ability to provide set-up and take-down services.
 - f. Describe in detail the warranty given on all equipment and service.
 - g. Identify any certifications and licenses that you the contractor and/or employee(s) may currently hold.
 - h. Describe the training, expertise, and supervision of personnel employed by the contractor that will be assigned to service this contract.
 - i. Include a list of manufacturer certifications or include a description of experience Offeror has on all equipment, systems, and supplies to be provided by the Offeror.
 - j. Provide resumes of key personnel that will be assigned to this tasking.

6. Offeror's Ability to Provide Types of Products/Services identified and the Quality of the Products/Services Offered (based on product list, descriptive literature, on-line capability, etc.).
 - a. Provide the internet address for your firm's online special event rental catalog, if available, or promotional material that provides photographs, descriptions, quantities available and pricing for offered items.
 - b. Describe seating options including the maximum number of uniform chairs that can be accommodated with one order. Include seating specifications, colors, etc. Provide descriptive literature, specifications and pictures of seating options being offered.
 - c. Describe staging options to include various sizes, styles, skirting, etc. Provide descriptive literature, specifications, and pictures of staging being offered.
 - d. Describe table options to include various sizes and styles. Provide descriptive literature, specifications and pictures of tables being offered.
 - e. Describe tent options to include various sizes and styles and associated cost. Provide descriptive literature, specifications and pictures of tents being offered.
 - f. Describe portable sanitation unit options to include various sizes and styles and associated cost. Provide descriptive literature, specifications, and pictures of comfort stations being offered.
 - g. Describe portable generator options to include various sizes and power capabilities. Provide descriptive literature, specifications, and pictures of generators being offered.
 - h. Provide information on other items your firm provides for special event rental.
7. Offeror's Specific Plans or Methodology to be used in performing services (including capability and plan of action to meet UMW demand signal for regularly scheduled key events, for short-fuse events, to address inclement weather alterations, etc.).
 - a. Describe timeframe for set-up and take-down of equipment.
 - b. Describe consultation and guidance that may be provided to UMW in determining exact needs for specific events and locations. Describe ability to accommodate requests for site visits to make recommendations and suggestions concerning equipment needed.
 - c. Describe in detail cancellation requirements.
 - d. Describe invoicing procedure and timelines. Provide sample invoice with proposal.
 - e. Unanticipated events may be held with little to no notice. Describe the expected turnaround time for events at UMW and how tight deadlines are met.
 - f. Provide any documented standard operating procedures that would mitigate risk to UMW.
 - g. Describe your staffing plan for delivery, set-up, operation, take-down and removal of equipment (numbers of employees, types of employees, responsibilities of employees).
 - h. Understanding Commonwealth of Virginia Higher Education requirements for Commencement Support for the same or similar timeframes, describe your capacity to meet that demand.
 - i. Describe any proposed subcontracting arrangements and expectations.
 - j. Describe your inclement weather procedures.
8. Pricing (prices, rebates, discounts, internships, sponsorships, etc.).
 - a. Complete pricing schedule attached (Attachment 3) by entering pricing information for all items that your company can provide.
 - b. Identify any offered discounts, rebates, opportunities for internships, sponsorships.
 - c. Identify any add-on charges proposed in complete detail (shipping by order, by load; by delivery; split order add-on charges; cancellation fees; credit card fees). Any add-on charges that are not identified in your original proposal will not be permitted under a resulting contract. It is imperative that you identify all potential add-on charges for consideration.
9. Submit any exceptions the Offering firm takes to the Terms and Conditions as stated in this RFP.

10. Include any other information the Offeror believes will help the University evaluate its proposal.

Please review the Proposal Submission Checklist, Attachment 6, prior to submission.

- VII. STATEMENT OF NEEDS:** UMW desires to secure the services of professional special event rental firms with direct experience and expertise in convention, event, or hospitality industry. In support of the awarded contract, the Contractor shall be responsible for the following:
- a. As required by the University, the Contractor shall provide goods and services for equipment rental, including outdoor tents, chairs, staging, tables, linens, generators, heaters, props, furniture, temporary structures, labor, insurance, supervision, incidentals, and other related supplies, services, furniture, and equipment, on an as-needed basis for special event rental services to the University.
 - b. Location of Contractor's Service Center must be within a 75-mile radius of the UMW's Main Campus, 1301 College Avenue, Fredericksburg, VA 22401.
 - c. Implementation and adherence to proper safety and health precautions to protect, at a minimum, all of its work, employees, the public and University personnel, students, and guests.
 - d. Equipment/Structures:
 - i. Contractor will deliver in-stock equipment in accordance with delivery expectations of the end user. Delivery time on any non-stock equipment will be detailed to the end-user prior to order placement.
 - ii. All equipment shall conform to any and all established manufacturer or industry standards and/or legally required laws, ordinances, and/or codes and shall be uniform, clean, superior quality, operable with no broken parts, and the same color within each ceremony/location. UMW will at its sole discretion determine if equipment is acceptable for use.
 - iii. The Contractor shall have in current stock, or available for rental at the required time, all equipment in sizes bid. Tents larger than 30' x 30' may be either framed or center pole.
 - iv. Contractor shall provide an event site diagram which includes rental equipment layouts, if needed. The contractor will provide verbal and written instructions for the use of equipment.
 - v. The Contractor will be provided a site visit prior to delivery of rental equipment at no additional charge to the University.
 - vi. All rentals will include set-up, break-down, and return of the site to its original condition unless the University requests otherwise.
 - vii. The Contractors shall adhere to all manufacturer, University and Commonwealth of Virginia requirements related to anchoring systems, side panels, lighting, exits, locations of heaters, generators, etc.
 - viii. The Contractor shall be responsible for monitoring weather conditions and may be required to cancel the erection/use of the structure should wind speed exceed manufacturer and Commonwealth requirements.
 - ix. Damages to listed equipment caused by the Contractor's negligence or nonfeasance shall be repaired at no cost to the University.
 - e. Requirements regarding Site Plans include, but are not limited to:
 - i. Temporary Structure Site Plans shall indicate distances from other occupied Buildings and Structures and the Use Group of these structures, if within 40 feet of the permit requested Temporary Structure.

- ii. Indicate on Site Plan(s) other site occurring/affecting items, such as: general site slope(s) and ground cover, sidewalks, paths, stairs, ramps, wheelchair egress/access, roadways, drives, trees, bushes, landscaping, bodies of water, other temporary structures and site improvements.
 - iii. For further information and for information on other temporary structures, the Contractor may be required to contact the Division of Engineering and Buildings (DEB) Lead Reviewer assigned to UMW to discuss the specific data and supporting documents which will be required.
- f. Licenses, Permits and Certifications:
- i. Contractor will be required to meet any/all license requirements stated within the contract at such time as the University has a project that needs to be fulfilled.
 - ii. Contractor must have personnel that are knowledgeable of “temporary structure permits” through the Commonwealth of Virginia and shall be trained and qualified to handle work of this type.
 - iii. Contractor shall be certified by the manufacturer or have established experience on all equipment, systems and supplies on which the firm will provide. The Contractor will provide documentation on manufacturer certification and/or references as requested by UMW throughout the duration of the contract.
 - iv. The University shall be responsible for obtaining permits for temporary structure through DEB. However, the Contractor may be required to assist the requesting Department with the following supporting documents for tents and other amusement devices:
 - 1) Site Plan, showing tent location and adjacent structures
 - 2) Floor Plans, with Exits shown
 - 3) Floor Plans, with Furnishing Layouts/Setups shown (e.g., tables, chairs, stages, food service, dance floor, etc.)
 - 4) Certificate of Conformance with NFPA 701 for Flame Resistance, if applicable.
- g. Failure to Perform or Deliver:
- i. Failure of the Contractor to deliver in the timeframe indicated may result in the University cancelling any order (or part of any order) without payment to the Contractor, and the University will not be held responsible for any restocking fee or penalty.
 - ii. Failure to provide equipment that has been scheduled and confirmed in advance shall be considered a failure to perform and may result in cancellation of the contract. All requests are understood by the Contractor to be dependent on availability. If the Contractor is unable to provide the scheduled equipment more than three (3) times during each contract year, the contract may be cancelled.
 - iii. Repeated failure to furnish materials on time, poor quality or unacceptable performance on the part of the contractor shall be deemed sufficient cause for cancellation of the agreement by the University.
- h. Contractor Employees:
- i. Contractor shall be responsible at all times for the actions and work of its employees. The contractor shall enforce strict discipline and good order among event personnel. UMW reserves the right to require the contractor to remove any employee whose behavior is deemed as unprofessional or objectionable.
 - ii. The contractor shall provide a sufficient number of qualified supervisors and employees to physically inspect, monitor or supervise the Contractor’s employees, ensuring adherence to the work schedule and quality of work.

- 1) One supervisor shall be appointed as main contact for the University's Contract Administrator.
 - 2) The supervisor shall be able to speak and read English fluently.
 - 3) It is expected that this person will report to the Contract Administrator or his/her designee daily when work is being performed under this contract.
- iii. Employee Conduct: The supervisor shall be responsible for the conduct and performance of the Contractor's employees, in addition to compliance with the following rules:
- 1) Contractor's employees appearing to be under the influence of alcohol or drugs shall not be permitted on University premises.
 - 2) No loud, boisterous or rude conduct shall be permitted.
 - 3) Contractor's employees shall not use or tamper with office machines nor use University telephones at any time.
 - 4) No smoking or vaping on UMW premises.
 - 5) No radios, no portable music sources, nor the use of residence hall televisions shall be permitted.
 - 6) No unauthorized personnel: The Contractor's employees are not to be accompanied in their work areas or on the premises by acquaintances, family members, or any other person unless said person is an authorized Contractor employee performing work under the contract.
- iv. Contractor shall assign a coordinator to review all billings to assure complete and accurate information and to act as contact person for the University.
- v. Contractor employees are required to wear uniforms to designate their affiliation at all times while on University property. Uniforms will contain the Contractor's name and the person's name designated on the upper portion of the shirt. Uniforms must remain consistent for proper identification purposes. The Selected Firm's personnel must have a photo ID with their name, company name, and be worn above the waist at all times. The University requires such identification for security precautions and access will be prohibited if University personnel do not recognize the identification.
- i. Communications:
- i. The Contractor shall designate a single company representative as the contact person for all rental requests. The designated representative shall advise UMW of equipment availability and shall confirm each rental.
 - ii. The Contractor shall identify and provide a contact person and a day and evening telephone number for emergency communications resulting from severe weather, faulty equipment, and all problems associated with the rental. If a change in the company representative occurs, the Contractor shall immediately notify the UMW representative ordering the equipment and/or UMW's Contract Administrator.
 - iii. Contractor will provide an answering service available for emergencies 24-hours a day, seven days a week.
- j. Pricing Schedule:
- i. The quantities shown in the Pricing Schedule are for the purposes of evaluation only; the one-day event rental prices (unit price) will set the baseline for pricing for future purchase

orders.

k. Damages/Insurance

- i. The Contractor is responsible for damages resulting from equipment failure that may cause personal injury to an Individual or to University facilities or equipment. The Contractor agrees to purchase such insurance over and above the University's stated minimum commercial general liability coverage that they consider necessary to protect their equipment from damage or destruction during the term of this contract. The Contractor also agrees that the University shall have no obligation for payment of damages of any nature to equipment provided. Contractor further understands and agrees that no employee of UMW, other than the designated Procurement Services department representative, is authorized to sign any rental or other agreement that contains terms and conditions other than those contained in this solicitation or in a purchase order issued against this solicitation, and that any signature of a University employee shall be interpreted as the University's acknowledgement of delivery only.
- ii. In addition to the above, the Contractor shall provide to the Purchasing Agent (Procurement Services) a Certificate of Insurance indicating that the Contractor has in force the coverage specified in the Terms and Conditions of this Solicitation/Contract.

l. Ordering Process:

- i. Develop clear, concise, and professional quality written quotes for each event for review and acceptance by UMW.
 - 1) Upon receipt of a written request from UMW, the contractor shall furnish a written description of the scope of services to be provided, ensuring mutual understanding and agreement of the services/work to be performed. The written description shall also include an estimate of the costs to complete the service, a set-up and pick-up date, expressed as either a definite date or the number of days after receipt of UMW's eVA purchase order.
 - a) Quoted prices for a specific event shall include any and all additional costs/fees associated with product procurement (such as, but not limited to, freight/shipping cost, crating fee, eVA transaction fee, processing fee, etc.).
- ii. Upon approval of the quote by the Events Office, an eVA purchase order will be issued as authority to proceed with the work. The eVA purchase order shall incorporate the contractor's quote as a "not to exceed" cost and the agreed upon delivery and pick-up time.
- iii. Request for rentals may be made by telephone, fax, or letter against a valid UMW Purchase Order Agreement.
- iv. The Contractor shall perform no work that would result in exceeding the dollar limitation of the eVA purchase order without first having obtained written approval from the Agency.
- v. The University will make every effort to provide the Contractor notice of such events no later than one (1) month prior to the event date.

VIII. CONTRACT ADMINISTRATION:

- A. The Executive Director of Events and catering, or designee, shall be identified by the University as the Contract Administrator and shall use all powers under the contract to enforce its faithfulness and performance in conjunction with the University’s Procurement Services department. Although resulting contracts may be assigned under Contract Administration to the Special Assistant to the President/University Events or their designee, other University departments shall retain the authority to utilize any resulting contracts.
- B. The Contract Administrator shall determine the amount, quantity, acceptability, fitness of all aspects of the goods/services and shall decide all other questions in connection with the goods/services. The Contract Administrator shall not have authority to approve changes in the goods/services which alter the concept or which call for an extension of the contract term. Any modifications made to the contract must be authorized by the University’s Procurement Services Department through a written two-party modification to the contract.

IX. EVALUATION AND AWARD CRITERIA

- A. Evaluation Criteria - Proposals shall be evaluated by the University of Mary Washington Evaluation Committee using the following criteria:

Criteria	Point Value
Offeror’s Qualifications and Experience in Providing Goods/Services (including experience with DEB, commitment of key personnel with qualifications and experience, past performance).	20
Offeror’s Ability to Provide Types of Products/Services identified and the Quality of the Products/Services Offered (based on product list, descriptive literature, on-line capability, etc.).	20
Offeror’s Specific Plans or Methodology to be used in performing services (including capability and plan of action to meet UMW demand signal for regularly scheduled key events, for short-fuse events, to address inclement weather alterations, etc.).	20
Pricing (prices, rebates, discounts, internships, sponsorships, etc.)	20
Small Business Subcontracting Plan	20
Total	100

X. GENERAL TERMS AND CONDITIONS:

Please refer to the link to follow regarding Required General Terms and Conditions of this Solicitation which are a mandatory part of the resulting contract: <https://adminfinance.umw.edu/procurement/umw-terms-conditions/>

XI. SPECIAL TERMS AND CONDITIONS:

- A. **ACCEPTANCE PERIOD:** Any proposal in response to this solicitation shall be valid for ninety (90) days from the closing date of the solicitation. At the end of the ninety (90) days the proposal may be withdrawn at the written request of the Contractor. If the proposal is not withdrawn within 10 calendar days at the end of the stated Acceptance Period, the proposal shall remain in effect, as-is, until an award is made, or the solicitation is canceled. If the proposal specifies an alternative acceptance period than the one written here, the acceptance period shall be the longer of the two dates.

- B. ACCESS TO WORK:** The University, the University’s inspectors and other test personnel, and inspectors from Department of Labor and Industry, DEB, or other agencies as appropriate, shall have access to the work at all times. The Contractor shall provide proper facilities for access and inspection.
- C. ADDITIONAL GOODS AND SERVICES:** The University reserves the right to request from the contractor to provide additional Goods and/or Services under similar and market-based pricing, terms, and conditions, and to make modifications or enhancements to existing services. Additional Goods and Services may include other products, components, accessories, subsystems or related services that are newly introduced during the term of the Agreement. Newly introduced additional Services will be provided to the University at favored nations pricing, terms, and conditions.
- D. ADVERTISING TO THE GENERAL PUBLIC:** In the event a contract is awarded for services resulting from this proposal, no indication of such services to the University of Mary Washington will be used in product literature or advertising. The Contractor shall not state in any of its advertising or product literature that the Commonwealth of Virginia or any agency or institution of the Commonwealth has purchased or uses its products or services.
- E. ANNOUNCEMENT OF AWARD:** Upon the award or the announcement of the decision to award a contract resulting from a competitive solicitation process for any dollar value, or sole source procurement, the University will publicly post such notice on the DGS/DPS eVA VBO (www.eva.virginia.gov) for a minimum of ten (10) days.
- F. ANTITRUST:** By entering into a contract, the contractor conveys, sells, assigns, and transfers to the Commonwealth of Virginia all rights, title and interest in and to all causes of action it may now have or hereafter acquire under the antitrust laws of the United States and the Commonwealth of Virginia, relating to the particular goods or services purchased or acquired by the Commonwealth of Virginia under said contract.
- G. AUDIT:** The contractor shall retain all books, records, and other documents relative to this contract for five (5) years after final payment, or until audited by the Commonwealth of Virginia, whichever is sooner. The agency, its authorized agents, and/or state auditors shall have full access to and the right to examine any of said materials during said period.
- H. AVAILABILITY OF FUNDS:** It is understood and agreed between the parties herein that the agency shall be bound hereunder only to the extent of the funds available or which may hereafter become available for the purpose of this agreement.
- I. AWARD – RFP:** Selection shall be made of two or more offerors deemed to be fully qualified and best suited among those submitting proposals on the basis of the evaluation factors included in the Request for Proposals, including price, if so stated in the Request for Proposals. Negotiations shall be conducted with the offerors so selected. Price shall be considered, but need not be the sole determining factor. After negotiations have been conducted with each offeror so selected, the agency shall select the offeror(s) which, in its opinion, has offered the best overall combination of quality, price and various elements of required goods/services, as stated in the solicitation, which in total are optimal relative to the agency’s need, and shall award the contract to that offeror(s). The University may cancel this Request for Proposal, reject proposals at any time prior to an award, and is not required to furnish a statement of the reasons why a particular proposal was not deemed to be the most advantageous (Governing Rule §16). Should the University determine in writing and in its sole discretion that only one offeror is fully qualified, or that one offeror is clearly more highly qualified than the others under consideration, or if in the sole opinion of the University it is in the University’s best interest to award to only one offeror, a contract may be negotiated and awarded to that Offeror. The award document will be a contract incorporating by reference all the requirements, terms and conditions of the solicitation and the contractor’s proposal as negotiated. The University, in its sole opinion, reserves the right, if determined to be in the best interest of the University, to make:
- i. a separate award of each item,

- ii. an award of a group of items,
- iii. an award either in whole or in part,
- iv. a single award, or
- v. a multiple award

- J. CANCELLATION OF CONTRACT:** The University reserves the right to cancel and terminate any resulting contract, in part or in whole, without penalty, upon sixty (60) days' written notice to the Contractor. Any contract cancellation notice shall not relieve the Contractor of the obligation to deliver and/or perform all outstanding orders issued prior to the effective date of cancellation. The Contractor shall be entitled to receive full compensation for all University-accepted services performed and/or goods received prior to the effective date of contract termination. Contractor shall not be entitled to, and hereby waives claims for lost profits and all other damages and expenses.
- K. CHANGES TO THE CONTRACT:** Changes can be made to the contract by written mutual agreement to modify the scope of the contract. An increase or decrease in the price of the contract resulting from such modification shall be agreed to by the parties as a part of their written agreement to modify the scope of the contract.
- L. CONTROLLING VERSION (for solicitation):** The PDF version of the solicitation and any addenda issued by University of Mary Washington Procurement Services is the mandatory controlling version of the document. Any modification and/or additions to the solicitation by the Offeror shall not modify the official version of the solicitation issued by UMW Procurement Services unless accepted in writing by the University. Such modifications or additions to the solicitation by the Offeror may be cause for rejection of the proposal; however, UMW reserves the right to decide on a case-by-case basis, in its sole discretion, whether to reject such a proposal. If the modifications or additions are not identified until after the award of the contract, the controlling version of the solicitation document shall still be the official state form (PDF) issued by UMW Procurement Services.
- M. CONTROLLING VERSION (for contract):** The PDF version of the contract issued by University of Mary Washington Procurement Services is the mandatory controlling version of the document. Any modification and/or additions by the Contractor shall not modify the official version of the contract issued by UMW Procurement Services unless accepted in writing by the University.
- N. COMPLIANCE:** Failure to comply with any of the specifications contained in the scope of work provided herein may result in cancellation of contract.
- O. CONTRACTOR REGISTRATION:** If a contract for construction, removal, repair or improvement of a building or other real property is for one hundred and twenty thousand dollars (\$120,000) or more, or if the total value of all such contracts undertaken by bidder/offeror within any 12-month period is seven hundred and fifty thousand (\$750,00) or more, the bidder/offeror is required under Title 54.1-1100, Code of Virginia (1950), as amended, to be licensed by the State Board of Contractors as a "CLASS A CONTRACTOR." If such a contract is for seventy-five hundred dollars (\$7,500) or more but less than one hundred and twenty thousand dollars (\$120,000), or if the total value of all such contracts undertaken by bidder/offeror within any 12-month period is between one hundred and fifty thousand dollars (\$150,000) and seven hundred and fifty thousand dollars (\$750,000) or more, the bidder is required to be licensed as a "CLASS B CONTRACTOR". If such a contract is for one-thousand dollars (\$1,000) or more, but less than seventy-five hundred dollars (\$7,500), or if the contractor does less than \$150,000 in business in a 12-month period, the bidder is required to be licensed as a "CLASS C CONTRACTOR". The board shall require a master tradesman license as a condition of licensure for electrical, plumbing and heating, ventilation and air conditioning contractors. The bidder/offeror shall place on the outside of the envelope containing the bid/proposal and shall place in the bid/proposal over his signature whichever of the following notations is appropriate, inserting his contractor license number:

Licensed Class A Virginia Contractor No. _____ Specialty _____
 Licensed Class B Virginia Contractor No. _____ Specialty _____

If the bidder/offeror shall fail to provide this information on his bid/proposal or on the envelope containing the bid/proposal and shall fail to promptly provide said contractor license number to the Commonwealth in writing when requested to do so before or after the opening of bids/proposals, he shall be deemed to be in violation of §54.1-1115 of the Code of Virginias (1950), as amended, and his bid/proposal will not be considered.

If a bidder/offeror shall fail to obtain the required license prior to submission of his bid/proposal, the bid/proposal shall not be considered.

- P. COOPERATIVE PROCUREMENT/ADDITIONAL USERS - USE OF AGREEMENT BY THIRD PARTIES:** It is the intent of this solicitation and resulting contract(s) to allow for cooperative procurement. Accordingly, any public body (to include government/state agencies, political subdivisions, etc.), cooperative purchasing organizations, public or private health or educational institutions, or any University affiliated agency and/or corporation may access any resulting contract if authorized by the Contractor. Use of this Agreement does not preclude any participating entity from using other agreements or competitive processes.

Participation in this cooperative procurement is strictly voluntary. If authorized by the Contractor(s), the resultant contract(s) will be extended to the entities indicated above to purchase goods and services in accordance with contract terms. As a separate contractual relationship, the participating entity will place its own orders directly with the contractor(s) and shall fully and independently administer its use of the contract(s) to include contractual disputes, invoicing and payments without direct administration from the University. No modification of this contract or execution of a separate agreement is required to participate; however, the participating entity and the contractor may modify the terms and conditions of this contract to accommodate specific governing laws, regulations, policies, and business goals required by the participating entity. Any such modification will apply solely between the participating entity and the Contractor.

The Contractor will notify the University in writing of any such entities accessing this Contract. The Contractor will provide semi-annual usage reports for all entities accessing the Contract. The University shall not be held liable for any costs or damages incurred by any other participating entity as a result of any authorization by the Contractor to extend the Contract. It is understood and agreed that the University is not responsible for the acts or omissions of any entity, and will not be considered in default of the Contract no matter the circumstances.

The Contractor is strongly encouraged to offer additional discounts to all contract participants as the result of increasing aggregated spend among all entities accessing the contract. A plan for extending deeper discounts among all contract participants will be requested during negotiations.

- Q. CRIMINAL BACKGROUND CHECKS OF PERSONNEL ASSIGNED BY CONTRACTOR TO PERFORM WORK ON UMW PROPERTY:** The Contractor shall obtain criminal background checks on all of their contracted employees who will be assigned to perform services on UMW property. The results of the background checks will be directed solely to the Contractor. The Contractor bears the responsibility for confirming to the University Contract Administrator that the background checks have been completed prior to the work being performed by their employees or subcontractors. The Contractor shall only assign to work on University properties those individuals whom it deems qualified and permissible based on the results of completed background checks. Notwithstanding any other provision herein, and to ensure the safety of students, faculty, staff and facilities, UMW reserves the right to approve or disapprove any contract employee that will work on UMW property. Disapproval by UMW will solely apply to UMW property and should have no bearing on the Contractor's employment of an individual outside of UMW.
- R. DRUG FREE WORKPLACE:** During the performance of this contract, the Contractor agrees to (i) provide a drug-free workplace for the Contractor's employees; (ii) post in conspicuous places, available to employees and applicants for employment, a statement notifying employees that the unlawful manufacture, sale, distribution,

dispensation, possession, or use of a controlled substance or marijuana is prohibited in the Contractor's workplace and specifying the actions that will be taken against employees for violations of such prohibition; (iii) state in all solicitations for advertisements for employees placed by or on behalf of the Contractor that the Contractor maintains a drug-free workplace; and (iv) include the provisions of the foregoing clause in every subcontract or purchase order of over \$10,000, so that the provisions will be binding upon each subcontractor or Contractor.

For the purposes of this section, "drug-free workplace" means a site for the performance of work done in connection with a specific contract awarded to a Contractor, the employees of who are prohibited from engaging in the unlawful manufacture, sale, distribution, dispensation, possession or use of any controlled substance or marijuana during the performance of the contract.

- S. DEFAULT:** In case of failure to deliver goods or services in accordance with the contract terms and conditions, the Commonwealth, after due oral or written notice, may procure them from other sources and hold the contractor responsible for any resulting additional purchase and administrative costs. This remedy shall be in addition to any other remedies which the Commonwealth may have.
- T. E-VERIFY PROGRAM:** Effective 12/1/2013, and pursuant to Code of Virginia, §2.2-4308.2., any employer with more than an average of 50 employees for the previous 12 months entering into a contract in excess of \$50,000 with any agency of the Commonwealth to perform work or provide services pursuant to such contract shall register and participate in the E-Verify program to verify information and work authorization of its newly hired employees performing work pursuant to such public contract. Any such employer who fails to comply with these provisions shall be debarred from contracting with any agency of the Commonwealth for a period up to one year. Such debarment shall cease upon the employer's registration and participation in the E-Verify program. If requested, the employer shall present a copy of their Maintain Company page from E-Verify to prove that they are enrolled in E-Verify.
- U. ENVIRONMENTAL LIABILITY:** Any costs or expenses associated with environmentally related violations of the law, the creation or maintenance of a nuisance, or releases of hazardous substances, including, but not limited to, the costs of any cleanup activities, removals, remediations, responses, damages, fines, administrative or civil penalties or charges imposed on the Contractor, whether because of actions or suits by any government or regulatory agency or by any private party, as a result of the storage, accumulation, or release of any hazardous substances, or any noncompliance with or failure to meet any federal, state or local standards, requirements, laws, statutes, regulations or the law of nuisance by Contractor (or by its agents, officers, employees, subcontractors consultants, sub-consultants, or any other persons, corporations or legal entities employed, utilized or retained by Contractor) in the performance of this Contract or related activities, shall be paid by Contractor. This paragraph shall survive the termination, cancellation or expiration of this Contract.
- V. EXCLUSIVITY:** The University reserves the right to procure goods or services covered under this contract from a third party when, in the University's sole discretion, it is deemed to be in the University's best interest.
- W. EXTRA CHARGES PROHIBITED:** The bid price shall be for the product and delivery, and shall include all applicable freight and transportation charges; extra charges will not be allowed.
- X. FINAL INSPECTION:** The contractor shall demonstrate to the authorized UMW representative that the work is fully operational and in compliance with contract specifications and code. Any deficiencies shall be promptly and permanently corrected by the contractor at the contractor's sole expense prior to final acceptance of the work.
- Y. FISCAL YEAR PROCESSING:** The University of Mary Washington's fiscal year is July 1st through June 30th. Payment cannot be made for multiple fiscal years in advance of services.

Z. FORMAL SOLICITATION COMMUNICATIONS/DISQUALIFICATION OF OFFERORS:

1. Informal Communications - From the date of receipt of this RFP by each Offeror until a binding contractual agreement exists with the selected contractor and all other Offerors have been notified, or when the University rejects all proposals, informal communication regarding this procurement shall cease. Informal communication shall include, but not be limited to:
 - I. Requests from Offerors to any departments of the University, with the exception of Purchasing, for information, comments, etc.
 - II. Requests from any department at the University of any employee of the Offeror, with the exception of Procurement Services, for information, comments, etc.
 - III. Contact with any individuals participating on the selection committee.
2. Formal Communications - From the date of receipt of this RFP by each Offeror, until a binding contractual agreement exists with the selected Offeror, and all other Offerors have been notified, or when the University rejects all proposals, all communications between the University and the Offerors will be formal as provided for in this RFP or as requested by Procurement Services. Formal communication shall include, but not be limited to:
 - I. Pre-proposal conference
 - II. Oral presentation, if requested
 - III. Site visits, etc.

AA. INDEMNIFICATION: Contractor agrees to indemnify, defend and hold harmless the Commonwealth of Virginia, its officers, agents, and employees from any claims, damages and actions of any kind or nature, whether at law or in equity, arising from or caused by the use of any materials, goods, or equipment of any kind furnished by the Contractor/any services of any kind or nature furnished by the Contractor, provided that such liability is not attributable to the sole negligence of the using agency or to failure of the using agency to use the materials, goods, or equipment in the manner already and permanently described by the Contractor on the materials, good or equipment delivered.

BB. INDEPENDENT CONTRACTOR RELATIONSHIP: In performing any and all of the services to be provided under this contract, the Contractor shall at all times and for all purposes be and remain an independent contractor. In no case and under no circumstances shall the Contractor or any of its employees, including but not limited to those of its employees actually performing any of the services, have authority to make any representations or commitments on behalf of the University or be considered the agent of the University for any purpose whatsoever. No persons engaged by the Contractor in connection with the provision of Services shall be considered employees of the University. As between the parties, the Contractor shall be responsible for hiring, supervising, training and instructing those individuals performing the services and shall pay any required state and federal taxes on behalf of such persons and provide them with any legally required employee benefits.

CC. INSPECTION: All work and materials in each project shall be subject to final inspection by an authorized representative of the University. Any omission or failure on the part of such representative to disapprove or reject inferior or defective work or materials shall not be construed to be an acceptance of any such work or material. If any defective work or materials are found during inspection, the contractor shall remove or repair, at his own expense, such defective work or rejected material and shall correct and/or replace same without extra charge.

DD. INSPECTION OF JOB SITE: Contractor certifies that they have inspected the job site and are aware of the conditions under which the work must be accomplished. Claims, as a result of failure to inspect the job site, will not be considered by the University.

EE. INSTALLATION: All items must be assembled and set in place, ready for use. All crating and other debris must be removed from the premises.

FF. INSURANCE: By signing this contract, the Contractor certifies it will have the following insurance coverage at the time the contract is awarded and through the term of each contract renewal period. For construction contracts, if any subcontractors are involved, the subcontractor will have worker's compensation insurance in accordance with §§ 2.2-4332 and 65.2-800 et. Seq. of the Code of Virginia. The Contractor further certifies that the Contractor and any subcontractors will maintain these insurance coverages during the entire term of the contract and that all insurance coverage's will be provided by insurance companies authorized to sell insurance in Virginia by the Virginia State Corporation Commission.

Minimum Insurance Coverages and Limits Required for Most Contracts:

1. Workers' Compensation - Statutory requirements and benefits. Coverage is compulsory for employers of three or more employees, to include the employer. Contractors who fail to notify the Commonwealth of increases in the number of employees that change their workers' compensation requirements under the Code of Virginia during the course of the contract shall be in noncompliance with the contract.
2. Employer's Liability - \$100,000.
3. Commercial General Liability - \$1,000,000 per occurrence and \$2,000,000 in the aggregate. Commercial General Liability is to include bodily injury and property damage, personal injury and advertising injury, products and completed operations coverage. The Commonwealth of Virginia must be named as an additional insured and so endorsed on the policy.
4. Automobile Liability - \$1,000,000 per occurrence (Only used if motor vehicle is to be used in the contract.)

GG. KEYS: If the Contractor is given keys for this project, it is the Contractor's responsibility to return the keys when the contract is terminated, as well as for the safekeeping of the keys during the contract period. The Contractor shall not loan or duplicate the keys. In the event the Contractor loses the keys, they will be charged for the replacement of the keys and any locks which are rekeyed or replaced.

HH. LATE PROPOSALS: To be considered for selection, proposals must be uploaded to eVa by the specified due date and time. After this deadline, eVa will not accept file uploads, resulting in the proposal not being submitted and contractor's ineligibility for contract award.

II. LIQUIDATED DAMAGES, FURNISH AND INSTALL: Work shall begin at the designated date and time requested by the contract administrator and all work shall be completed by the date and time stated on the purchase order. It is hereby understood and agreed by the contractor that time is of the essence in the delivery of supplies, services, materials, or equipment of the character and quality specified. In the event these specified supplies, services, materials, or equipment are not delivered by the date specified, the contractor will be responsible for re-procurement costs including, but not limited to, contracting with a new vendor to complete the necessary services; except that if the delivery be delayed by act, negligence or default on the part of the Commonwealth, public enemy, war, embargo, fire, or explosion not caused by the negligence or intentional act of the contractor or his supplier(s), or by riot, sabotage, or labor trouble that results from cause or causes entirely beyond the control or fault of the contractor or his supplier(s), a reasonable extension of time as the procuring public body deems appropriate may be granted. Upon receipt of a written

request and justification for an extension from the contractor, the purchasing office may extend the time for performance of the contract or delivery of goods herein specified at the purchasing office's sole discretion for good cause shown.

JJ. MISS UTILITIES: As required, it shall be the Contractor's responsibility to contact Miss Utilities a minimum of forty-eight (48) hours prior to installation to have all existing underground utilities located, and shall be responsible for any damage to the underground utilities during the performance of this contract.

KK. OPERATING VEHICLES ON UMW CAMPUS: Operating Contractor vehicles on sidewalks, plazas, grass, flower beds, walkways, fountains, and University seal is prohibited. The safety of our students, faculty and staff is of paramount important to us. Accordingly, violators may be charged.

LL. ORDERING PROCEDURES: The awardee of a contract under this solicitation shall be issued one (1) master contract, which will be valid for the term of the contract. Individual purchase orders will be issued on a per occurrence basis when goods are required. Each purchase order will reference the particular goods to be provide and the master contract number.

MM. PERMITS:

1. The University will be responsible to obtain all necessary permits for work directed under this contract.
2. The Contractor shall comply with all applicable federal, state, and local laws, codes, and regulations in connection with the accomplishment of work under this contract. The Contractor shall be responsible for all damages to persons and/or property that occur as a result of his fault or negligence. He shall take proper safety and health precautions to protect the work, the workers, the public and the property.

NN. PREBID/PREPROPOSAL CONFERENCE – OPTIONAL: An optional preproposal conference will be held at 10:00 a.m., June 12, 2025 at the Eagle Village Executive Offices, Suite 480, 1125 Emancipation Hwy., Fredericksburg, VA 22401. The purpose of this conference is to allow potential offerors an opportunity to present questions and obtain clarification relative to any facet of this solicitation. While attendance at this conference will not be a prerequisite to submitting a proposal, offerors who intend to submit a proposal are encouraged to attend. Bring a copy of the solicitation with you. Any changes resulting from this conference will be issued in a written addendum to the solicitation.

OO. PRICE ESCALATION/DE-ESCALATION:

1. Price adjustments may be permitted for changes in the contractor's cost of materials and are only authorized at time of renewal (exercise of option periods) and only if formally documented in a corresponding contract modification. However, "across the board" price decreases are subject to implementation at any time and shall be immediately conveyed to the University.
2. Contractor shall give not less than ninety (90) days advance notice of any price increase to the Procurement office. Any approved price changes will be effective only at the beginning of the term of the next option period. The contractor shall document the amount and proposed effective date of any general change in the price of materials. Documentation shall be supplied with the contractor's request for increase which will:
 - I. Verify that the requested price increase is general in scope and not applicable just to the University
 - II. Verify the amount or percentage of increase which is being passed on to the contractor by the contractor's suppliers.
3. The Procurement office will notify the using agencies and contractor in writing of the effective date of any increase which it approves. However, the contractor shall fill all purchase orders received prior to the effective date of the price adjustment at the old contract prices. The contractor is further advised that

decreases which affect the cost of materials are required to be communicated immediately to the Procurement office.

PP. PROPOSAL ACCEPTANCE PERIOD: Any offer in response to this solicitation shall be valid for ninety (90) days. At the end of the 90 days the proposal may be withdrawn at the written request of the offeror. If the proposal is not withdrawn at that time it remains in effect until an award is made or the solicitation is canceled.

QQ. PUBLIC POSTING OF COOPERATIVE CONTRACTS: UMW maintains a web-based contracts database with a public gateway access. Any resulting cooperative contract to this solicitation will be posted to the publicly accessible website. Contents identified as proprietary information will not be made public.

RR. RECYCLING POLICY: It shall be the policy of the University of Mary Washington to support and encourage conservation and recycling efforts by vendors, students, faculty and staff.

SS. RENEWAL OF CONTRACT: This contract may be renewed by the Commonwealth for five (5) successive periods, or as negotiated, under the terms and conditions of the original contract except stated in 1. and 2. below. Price increases may be negotiated only at the time of renewal. Written notice of the Commonwealth's intention to renew shall be given approximately 90 days prior to the expiration date of each contract period.

1. If the University elects to exercise the option to renew the contract for an additional one- year period, the contract price(s) for the additional one year shall not exceed the contract price(s) of the original contract increased/decreased by more than the percentage increase/decrease of all the services category of the CPI-U section of the Consumer Price Index of the United States Bureau of Labor Statistics for the latest twelve months for which statistics are available.
2. If during any subsequent renewal periods, the Commonwealth elects to exercise the option to renew the contract, the contract price(s) for the subsequent renewal period shall not exceed the contract price(s) of the previous renewal period increased/decreased by more than the percentage increase/decrease of the all services category of the CPI-W section of the Consumer Price Index of the United States Bureau of Labor Statistics for the latest twelve months for which statistics are available.

TT. SMALL BUSINESS SUBCONTRACTING AND EVIDENCE OF COMPLIANCE: It is the goal of the Commonwealth that 42% of its purchases are made from small businesses. This includes discretionary spending in prime contracts and subcontracts. All potential bidders/offerors are required to submit a Small Business Subcontracting Plan. Unless the bidder/offeror is registered as a Virginia Department of Small Business and Supplier Diversity (DSBSD)-certified small business and where it is practicable for any portion of the awarded contract to be subcontracted to other suppliers, the contractor is encouraged to offer such subcontracting opportunities to DSBSD-certified small businesses. This shall not exclude DSBSD-certified women-owned and minority-owned businesses when they have received DSBSD small business certification. No bidder/offeror or subcontractor shall be considered a Small Business, a Women- Owned Business or a Minority-Owned Business unless certified as such by the DSBSD by the due date for receipt of bids or proposals. If small business subcontractors are used, the prime contractor agrees to report the use of small business subcontractors by providing the purchasing office at a minimum the following information: name of small business with the DSBSD certification number, phone number, total dollar amount subcontracted, category type (small, women-owned, or minority-owned), and type of product/service provided.

- i. Each prime contractor who wins an award in which provision of a small business subcontracting plan is a condition of the award, shall deliver to the contracting agency or institution on a monthly or quarterly basis, evidence of compliance (subject only to insubstantial shortfalls and to shortfalls arising from subcontractor default) with the small business subcontracting plan. When such business has been

subcontracted to these firms and upon completion of the contract, the contractor agrees to furnish the purchasing office at a minimum the following information:

- I. Name of firm with the DSBSD certification number
- II. Phone number
- III. Total dollar amount subcontracted
- IV. Category type (small, women-owned, or minority-owned)
- V. Type of product or service provided

Payment(s) may be withheld until compliance with the plan is received and confirmed by the agency or institution. The agency or institution reserves the right to pursue other appropriate remedies to include, but not be limited to, termination for default.

2. Each prime contractor who wins an award valued over \$200,000 shall deliver to the contracting agency or institution on a monthly or quarterly basis, information on use of subcontractors that are not DSBSD-certified small businesses. When such business has been subcontracted to these firms and upon completion of the contract, the contractor agrees to furnish the purchasing office at a minimum the following information: name of firm, phone number, total dollar amount subcontracted, and type of product or service provided.

UU. STANDARDS OF CONDUCT: The work site will be occupied by students and University Personnel during the times work is performed. Contractor and Contractor's personnel shall exercise a particularly high level of discipline, safety and cooperation at all times while on the job site. The Contractor shall be responsible for controlling employee conduct, for assuring that its employees are not boisterous or rude, and assuring that they are not engaging in any destructive or criminal activity. The Contractor is also responsible for ensuring that its employees do not disturb papers on desks, or open drawers, cabinets, or briefcases, or use State phones, and the like, except as authorized.

UMW, an agency of the Commonwealth of Virginia, strictly forbids harassment of any employee, applicant for employment, vendor, contractor or volunteer in the workplace*, or on the basis of an individual's race, sex, color, national origin, religion, sexual orientation, age, veteran status, political affiliation or disability. The Commonwealth will not tolerate any form of retaliation directed against an employee or third party* who either complains about harassment or who participates in any investigation concerning harassment.

The Commonwealth expressly prohibits workplace violence*. Prohibited conduct includes, but is not limited to: Injuring another person physically; Engaging in behavior that creates a reasonable fear of injury to another person; Engaging in behavior that subjects another individual to extreme emotional distress; Possessing, brandishing, or using a weapon that is not required by the individual's position while on state premises or engaged in state business; Intentionally damaging property; Threatening to injure an individual or to damage property; Committing injurious acts motivated by, or related to, domestic violence or sexual harassment; and Retaliating against any employee who, in good faith, reports a violation of this policy.

Violations of the above standards of conduct may result in requests for apparent offenders to temporarily or permanently leave the workplace.

VV. STATE CORPORATION COMMISSION IDENTIFICATION NUMBER: Pursuant to Code of Virginia, §2.2-4311.2 Section B, a bidder or offeror organized or authorized to transact business in the Commonwealth pursuant to

Title 13.1 or Title 50 is required to include in its bid or proposal the Identification number issued to it by the State Corporation Commission (SCC). Any bidder or offeror that is not required to be authorized to transact business in the Commonwealth as a foreign business entity under Title 13.1 or Title 50 or as otherwise required by law is required to include in its bid or proposal a statement describing why the bidder or offeror is not required to be so authorized. Indicate the above information on the SCC Form provided. Contractor agrees that the process by which compliance with Title 13.1 and 50 is checked during the solicitation stage (including without limitation the SCC Form provided) is streamlined and is not definitive, and the Commonwealth's use and acceptance of such form, or its acceptance of Contractor's statement describing why the bidder or offeror was not legally required to be authorized to transact business in the Commonwealth, shall not be conclusive of the issue and shall not be relied upon by the Contractor as demonstrating compliance. Reference Attachment 1.

WW. SUBCONTRACTS: No portion of the work shall be subcontracted without prior written consent of the purchasing agency. In the event that the contractor desires to subcontract some part of the work specified herein, the contractor shall furnish the purchasing agency the names, qualifications and experience of their proposed subcontractors. The contractor shall, however, remain fully liable and responsible for work to be done by its subcontractor(s) and shall assure compliance with all requirements of the contract.

The contractor shall be responsible for completely supervising and directing the work done under this contract by subcontractors that may be utilized in support of the contract, using the contractor's best skill and attention. Subcontractors performing work under this contract shall be accountable to the prime contractor.

XX. SUBMISSION OF INVOICES: All invoices shall be submitted within thirty (30) days of contract term expiration for the initial contract period as well as for each subsequent contract renewal period. Any invoices submitted after the thirty (30) day period will not be processed for payment.

YY. UNDERSTANDING OF REQUIREMENTS: It is the responsibility of each offeror to inquire about and clarify any requirements of this solicitation that is not understood. The University will not be bound by oral explanations as to the meaning of specifications or language contained in this solicitation. Therefore, all inquiries deemed to be substantive in nature must be in writing and submitted to the responsible buyer in the Procurement Services Office. Offerors must ensure that written inquiries reach the buyer at least fourteen (14) days prior to the time set for receipt of proposals. A copy of all queries and the respective response will be provided in the form of an addendum. Your signature on your Offer certifies that you fully understand all facets of this solicitation.

ZZ. USE OF PREMISES AND REMOVAL OF DEBRIS: The contractor shall:

1. Perform his contract in such a manner as not to interrupt or interfere with the operation of any existing activity on the premises or with the work of any contractor;
2. Store his apparatus, materials, supplies, and equipment in such orderly fashion at the site of the work as will not unduly interfere with the progress of his work or the work of any other contractor; and
3. Place upon the work or any part thereof only such loads as are consistent with the safety of that portion of the work.
4. To clean up frequently all refuse, rubbish, scrap materials, and debris caused by his operations, to the end at all times the site of the work shall present a neat, orderly and workmanlike appearance.
5. Vehicle parking shall be permitted in designated areas. Contractor shall obtain approval from the Contract Administrator for parking in other areas.

AAA. WARRANTY OF MATERIALS AND WORKMANSHIP: The Contractor warrants that, unless otherwise specified, all materials and equipment incorporated in the work under the contract be new, in first class condition, and in accordance with the contract documents. The Contractor further warrants that all workmanship shall be of the highest quality and in accordance with contract documents and shall be performed by persons qualified at their respective trades. Work not conforming to these warranties shall be considered defective. This warranty of materials and workmanship is separate and independent from and in addition to any of the Contractor's other guarantees or obligations in this contract.

BBB. WORK SITE DAMAGES: Any damage to existing utilities, equipment or furnished surfaces resulting from the performance of this contract shall be repaired to the Commonwealth's satisfaction at the contractor's expense.

CCC. WORK SITE USE: The Contractor expressly undertakes, either directly or through its Subcontractor(s):

1. To comply with the regulations governing the operation of premises and to perform its contract in such a manner as not to interrupt or interfere with the operation of any existing activity on the premises or at the location of the work.
2. To store all apparatus, materials, supplies and equipment in such orderly fashion at the site of the work as will not unduly interfere with the progress of the work or the University's use of the facilities.
3. To place upon the work or any part thereof only such loads as are consistent with the safety of that portion of the work.
4. To clean up frequently all refuse, rubbish, scrap materials, and debris caused by his operation, to the end that all times the site of the work shall present a neat, orderly and workmanlike appearance.

DDD. CONFLICT OF TERMS: In the event of any inconsistency or conflict between the provisions of this Agreement and any other related rental agreements, policies, or documents referenced herein, the terms of this Agreement shall prevail.

XIII. SUPPLIER ONBOARDING and METHOD OF PAYMENT: *All awarded Contractors must be [registered with the University](#) to receive payment via University-issued check or ACH.* The Contractor shall be paid using one of the following methods for all University initiated procurements:

1. University Charge Card: At the time of verified receipt of goods or services, and proper invoice, if the Contractor's eVA profile indicates acceptance of credit cards in payment, the University will authorize payment by University charge card, currently through the Bank of America Visa, under the following terms:
 - a. Any "Check-out fees" imposed by the contractor must be disclosed prior to the purchase.
 - b. No check-out fee or surcharge, that was appropriately disclosed in advance of the sale/purchase, shall be greater than 3% of the total sale., effective 4/15/2023. The University expects that these costs, as well as all contractor business expenses will be built into the contractor's quoted price.
2. Virtual Payables through Bank of America: All payments made under Virtual Payables will have a net 16 payment term. For more information about this payment option, contact UMW's Accounts Payable department at: payables@umw.edu or view <http://www.bankofamerica.com/epayablesvendors>.
3. UMW Check or ACH: *Payment will be made per the terms of the contract, or 30 days after satisfactory performance of the contract in all provisions thereof and upon receipt of a properly completed invoice, whichever is later; in accordance with Chapter 43, VPPA, Article 4, Code of Virginia.*

NOTE: ACH must be set up in advance prior to submittal of any invoices.
<https://www.doa.virginia.gov/reference.shtml#edi>

To be considered eligible for payment, **all physical invoices must be received at the address below** and should reference the eVA purchase order and UMW contract numbers as applicable. **All electronic invoices must be sent to invoices@mail.umw.edu**. *The University will not be responsible for late payment or nonpayment of invoices not received directly by Accounts Payable at this email address or at the mailing address indicated (below).*

UNIVERSITY OF MARY WASHINGTON
Attn: ACCOUNTS PAYABLE
1301 COLLEGE AVENUE
FREDERICKSBURG, VA 22401

XIV. ATTACHMENTS:

The following Attachments are provided herein for completion by the Offeror and included within the proposal submission:

- Attachment 1. Single, Emergency and Administrative Point of Contact Identification Sheet
- Attachment 2. Contractor Data Sheet
- Attachment 3. Pricing Schedule
- Attachment 4. SWAM Subcontracting Plan
- Attachment 5. Subcontracting spend Reporting
- Attachment 6. Proposal Checklist
- Attachment 7. Staging Diagram

ATTACHMENT 1
POINT OF CONTACT INFORMATION SINGLE POINT OF CONTACT
RETURN THIS FORM WITH YOUR PROPOSAL PACKAGE

PRIMARY POINT OF CONTACT

CONTACT PERSON'S NAME	
CELL PHONE NUMBER	
IS CELL PHONE CAPABLE OF RECEIVING TEXT MSGS?	
BEEPER/PAGER NUMBER	
TELEPHONE NUMBER – NORMAL WORKING HOURS	
TELEPHONE NUMBER – AFTER WORKING HOURS	
FAX NUMBER	
EMAIL ADDRESS	

EMERGENCY POINT OF CONTACT

CONTACT PERSON'S NAME	
CELL PHONE NUMBER	
IS CELL PHONE CAPABLE OF RECEIVING TEXT MSGS?	
BEEPER/PAGER NUMBER	
TELEPHONE NUMBER – NORMAL WORKING HOURS	
TELEPHONE NUMBER – AFTER WORKING HOURS	
FAX NUMBER	
EMAIL ADDRESS	

(Attachment 1 Continued)

INVOICING/PAYMENT POINT OF CONTACT

CONTACT PERSON'S NAME	
CELL PHONE NUMBER	
IS CELL PHONE CAPABLE OF RECEIVING TEXT MSGS?	
BEEPER/PAGER NUMBER	
TELEPHONE NUMBER – NORMAL WORKING HOURS	
TELEPHONE NUMBER – AFTER WORKING HOURS	
FAX NUMBER	
EMAIL ADDRESS	

ATTACHMENT 2 CONTRACTOR DATA SHEET
RETURN THIS COMPLETED FORM WITH YOUR PROPOSAL PACKAGE

QUALIFICATION OF CONTRACTOR: The Contractor must have the capability and capacity in all respects to fully satisfy all of the contractual requirements.

- **YEARS IN BUSINESS:** Indicate the length of time in business providing this type of service.

_____ **Years** _____ **Months**

- **REFERENCES:** Indicate below a list of at least four (4) recent references, either commercial or governmental, for which this type of service has been provided. Include the date the service was furnished, and the name and address of the person the University has permission to contact, date of service, value or order, and contract number:

Name & Address	Contact Person	Email Address	Telephone Number	Description of Work & Date Completed

ATTACHMENT 3-- PRICING SCHEDULE

RETURN THIS FORM WITH YOUR PROPOSAL PACKAGE

The Contractor agrees to provide the services in compliance with the scope of work for each specific line item/services at a firm fixed price for the period of this agreement as follows.

In any instance where the contractor cannot provide the required services within an acceptable timeframe, the University reserves the right to purchase these services on the open market.

The quantities are estimated quantities used for evaluation purposes only. The University reserves the right to purchase those services actually needed and in quantities as required by the University regardless of whether such total quantities are more or less than those shown.

Item No	Description	Daily Rental	Quantity	Unit	Total
	TENTS and Canopies (Provide, Install, and Remove)				
	To include poles and concrete anchors, courtyard tents (all require concrete anchors)				
1	Tents, 10' x 10', Standard Tent	\$		Each	\$
2	Tents, 10' x 10', High Peaked	\$		Each	\$
3	Tents, 15' x 15'	\$			
4	Tents, 15' x 30'	\$		Each	\$
5	Tents, 20' x 20'	\$		Each	\$
6	Tents, 30' x 30'	\$		Each	\$
7	Tents, 30' x 40'	\$		Each	\$
8	Tents, 30' x 45'	\$		Each	\$
9	Tents, 30' x 50'	\$		Each	\$
10	Tents, 30' x 60'	\$		Each	\$
11	Tents, 30' x 75'	\$		Each	\$
12	Tents, 40' x 80'	\$		Each	\$
13	Tents, 60' x 100'	\$		Each	\$
14	Tents, 80' x 100'	\$		Each	\$
15	Tents, 80' x 210"	\$		Each	\$
16	Clear Top Tent, 30' x 30'	\$		Each	\$
17	Clear Top Tent, 30' x 40'	\$		Each	\$
18	Clear Top Tent, 30' x 45'	\$		Each	\$
19	Clear Top Tent, 30' x 50'	\$		Each	\$
20	Clear Top Tent, 30' x 60'	\$		Each	\$
21	Clear Top Tent, 30' x 30'	\$		Each	\$
22	Clear Top Tent, 30' x 75'	\$		Each	\$
23	Clear Top Tent, 30' x 90'	\$		Each	\$
24	Clear Top Tent, 40' x 45'	\$		Each	\$
25	Clear Top Tent, 40' x 50'	\$		Each	\$
26	Clear Top Tent, 40' x 60'	\$		Each	\$
27	Clear Top Tent, 40' x 80'	\$		Each	\$
28	Clear Top Tent, 40' x 100'	\$		Each	\$
29	Clear Peak Tent, 10' x 10'	\$		Each	\$
30	Clear Peak Tent, 10' x 20'	\$		Each	\$
31	Clear Peak Tent, 15' x 15'	\$		Each	\$
32	Clear Peak Tent, 20' x 20'	\$		Each	\$

33	Clear Peak Tent, 20' x 30'	\$		Each	\$
34	Clear Peak Tent, 20' x 40'	\$		Each	\$
35	Sail Cloth Tent, 45' x 44'	\$		Each	\$
36	Sail Cloth Tent, 45' x 64'	\$		Each	\$
37	Sail Cloth Tent, 45' x 84'	\$		Each	\$
38	Sail Cloth Tent, 45' x 104'	\$		Each	\$
TENT Accessories (Provide, Install, and Remove)					
39	Concrete Anchors	\$		Each	\$
40	Concrete Covers	\$		Each	\$
41	Tent Pole Covers	\$		Each	\$
42	Tent Liner for Each Size Tent	\$		Each	\$
43	Tent Lights, Bistro – Black and White	\$		Each	\$
44	Tent Lights, Lanterns, Japanese 12", 16", 20" and 24"	\$		Each	\$
45	Tent Fan	\$		Each	\$
46	Tent Fan - 12"	\$		Each	\$
47	Tent Fan – 18"	\$		Each	\$
48	Drum Fan, 24"	\$		Each	\$
49	Tent Gutter	\$		Each	\$
TABLES (Rental, Set-up, Breakdown)					
50	Banquet Rectangular 4' x 30"	\$		Each	\$
51	Banquet Rectangular 6' x 30"	\$		Each	\$
52	Banquet Rectangular 8' x 30"	\$		Each	\$
53	Banquet Rectangular 6' x 18"	\$		Each	\$
54	Banquet Rectangular 8' x 18"	\$		Each	\$
55	Banquet Rectangular 8' x 30" Children's Table	\$		Each	\$
56	Banquet Round 3'	\$		Each	\$
57	Banquet Round 4'	\$		Each	\$
58	Banquet Round 5'	\$		Each	\$
59	Banquet Round 6'	\$		Each	\$
60	Cocktail Rounds Tall and Standard Heights 24"	\$		Each	\$
61	Cocktail Rounds Tall and Standard Heights 30"	\$		Each	\$
62	Square 2', Standard and High Top	\$		Each	\$
63	Square 4', Standard	\$		Each	\$

64	Square 5', Standard	\$		Each	\$
65	Serpentine 8'	\$		Each	\$
66	Timberwood Farm Table, 4' x 8'	\$		Each	\$
67	Timberwood Benches for Farm Table	\$		Each	\$
68	King Table, 4' x 8' Rectangular Table	\$		Each	\$
CHAIRS (Rental, Set-up, Breakdown)					
69	Padded Garden, White, Black and Natural	\$		Each	\$
70	Folding Black, White, and Tan	\$		Each	\$
71	Chivari Barstool, Black and Natural, mahogany,	\$		Each	\$
72	Chivari Black, Gold, Silver, Mahogany, and White	\$		Each	\$
73	Set Up/ Knock Down of Chairs	\$		Each	\$
STAGE SECTIONS, 4' X 8' (PROVIDE, INSTALL, AND REMOVE)					
74	Stage, 12" High	\$		Each	\$
75	Stage, 32" High	\$		Each	\$
STAGE EQUIPMENT (PROVIDE, INSTALL AND REMOVE)					
76	Staging (Risers 4 x 4)	\$		Each	\$
77	Staging Steps	\$		Each	\$
78	Black Astroturf Covering for Stage	\$		Each	\$
79	4' Guard Rails for Staging	\$		Each	\$
80	ADA Access Ramps by the Foot	\$		Each	\$
STAIRS (PROVIDE, INSTALL AND REMOVE)					
81	Stairs, 12" High	\$		Each	\$
82	Stairs, 32" High	\$		Each	\$
PIPES AND DRAPES (RENTAL ONLY)					

83	10' High Black, Navy Blue and Royal Blue, White	\$		Each	\$
84	12' High Black, Navy Blue and Royal Blue, White	\$		Each	\$
85	20' High Black, Navy Blue and Royal Blue, White	\$		Each	\$
STANCHIONS (RENTAL ONLY)					
86	36" High, without Rope	\$		Each	\$
87	White Plastic with White Plastic Chain	\$		Each	\$
STANCHIONS CHROME PORTA POST					
88	6' Section Red and Black Velour Rope	\$		Each	\$
89	8' Section Red and Black Velour Rope	\$		Each	\$
ARCHES (PROVIDE, INSTALL AND REMOVE)					
90	Wood	\$		Each	\$
COLUMN (PROVIDE, INSTALL AND REMOVE)					
91	33"	\$		Each	\$
92	46"	\$		Each	\$
93	56"	\$		Each	\$
94	76"	\$		Each	\$
95	Stage Façade, 3' x 4'	\$		Each	\$
96	Bar Top for Rectangular Table and Skirting, 6'	\$		Each	\$
SCREEN (PROVIDE, INSTALL AND REMOVE)					
97	6 Panel Bi-Fold Screen, White	\$		Each	\$
LOUNGE FURNITURE (PROVIDE, INSTALL AND REMOVE)					
98	Sectional Full Sofa	\$		Each	\$
99	Sectional Love Seat	\$		Each	\$
100	Sectional Arm Chair	\$		Each	\$

101	Sectional Ottoman	\$		Each	\$
FLOORING (PROVIDE, INSTALL AND REMOVE)					
102	Deck Flooring	\$		Each	\$
103	Dance Floor	\$		Each	\$
104	25' Red Carpet	\$		Each	\$
105	50' Red Carpet	\$		Each	\$
MISCELLANEOUS (PROVIDE, INSTALL AND REMOVE)					
106	6' Bar Tops for Rectangular Tables	\$		Each	\$
107	Portable Bar	\$		Each	\$
BAR					
108	Portable Acrylic Bar	\$		Each	\$
COMMENCEMENT STAGING	See requirements for staging along with diagrams (Reference Attachment 7 to this RFP)	\$		Each	\$
DELIVERY		(Per Order)	(Flat Rate)		
109	Delivery and Pickup Charge, Flat Rate, for Chairs, Tables, Pipe and Drapes, Stanchions, and other items as Required.	\$	\$	Events	\$
TOTAL NET PRICING:					\$
110	Informational Pricing: The Contractor offers to the University the following discount from the contractor's standard published list price in effect at the time of the rental for all items not listed above % - Listed Price				

ATTACHMENT 4 -- SMALL BUSINESS SUBCONTRACTING PLAN
MUST BE COMPLETED AND RETURNED WITH PROPOSAL

All small businesses must be certified by the Commonwealth of Virginia, Department of Small Business and Supplier Diversity (DSBSD) by the due date of the solicitation to participate in the SWaM program. Certification applications are available through DSBSD online at <http://sbsd.virginia.gov>.

DEFINITIONS:

"Micro Business" means a business that is a certified Small Business under the SWaM Program and has no more than twenty-five (25) employees and no more than \$3million in average annual revenue over the three-year period prior to their certification.

"Small business" means a business independently owned and controlled by one or more individuals who are U.S. citizens or legal resident aliens, and together with affiliates, has 250 or fewer employees, or average annual gross receipts of \$10 million or less averaged over the previous three years. One or more of the individual owners shall control both the management and daily business operations of the small business. *Note: DSBSD-certified women- and minority-owned businesses shall also be considered small businesses when they have received DSBSD small business certification. (Code of Virginia, § 2.2-4310)*

"Woman-owned business" means a business that is at least 51% owned by one or more women who are U.S. citizens or legal resident aliens, or in the case of a corporation, partnership, or limited liability company or other entity, at least 51% of the equity ownership interest is owned by one or more women who are U.S. citizens or legal resident aliens, and both the management and daily business operations are controlled by one or more women. *(Code of Virginia, § 2.2-4310)*

"Minority-owned business" means a business that is at least 51% owned by one or more minority individuals who are U.S. citizens or legal resident aliens, or in the case of a corporation, partnership or limited liability company or other entity, at least 51% of the equity ownership interest in the corporation, partnership, or limited liability company or other entity is owned by one or more minority individuals who are U.S. citizens or legal resident aliens, and both the management and daily business operations are controlled by one or more minority individuals. *(Code of Virginia, § 2.2-4310)*

Bidder Name: _____

Preparer Name: _____ **Date:** _____

INSTRUCTIONS:

- A. If you are certified by the Department of Small Business and Supplier Diversity (DSBSD) as a small business, complete only Section A of this form. This shall not exclude DSBSD-certified women-owned and minority-owned businesses when they have received DSBSD small business certification.
- B. If you are not a DSBSD-certified small business, complete Section B of this form. For the bid to be considered and the bidder to be declared responsive, the bidder shall identify the portions of the contract that will be subcontracted to DSBSD-certified small business in Section B.

ATTACHMENT 4 (CONT'D)

Section A

If you are certified by the Department of Small Business and Supplier Diversity (DSBSD), are you certified as a:

Check All That Apply: Micro Business Small Business Woman-Owned Business Minority-Owned Business

DSBSD Certification No.: _____ Expiration Date: _____

Section B

Populate the table below to show your plans for utilization of DSBSD-certified small businesses in the performance of this contract. This shall not exclude DSBSD-certified women-owned and minority-owned businesses that have received the DSBSD small business certification. Include plans to utilize small businesses as part of joint ventures, partnerships, subcontractors, suppliers, etc.

Plans for Utilization of DSBSD-Certified Small Businesses for this Procurement

Small Business Name, Address & DSBSD Cert No.	Indicate if also: Micro (O), Women (W), or Minority (M) Certified	Contact Person, Telephone & Email	Type of Goods and/or Services	Planned Involvement During Initial Period of the Contract (%)	Planned Contract Dollars During Initial Period of the Contract (\$)
Total Planned Subcontracting Spend (\$)					

ATTACHMENT 5 -- SMALL BUSINESS SUBCONTRACTING PLAN

FORM LOCATED ON PROCUREMENT SERVICES WEBSITE

<http://adminfinance.umw.edu/procurement/vendors-2/swam-reporting/>

UNIVERSITY OF MARY WASHINGTON

Administration and Finance

Procurement Services

Laws, Policies and Procedures | Buyer Resources | SPCC | Technology Purchases | Vendors | UMW Supplier Expo

Forms
DSBSD – SWaM
Contracts
Contact Us

QUICK LINKS

Vendor Resources
Vendor Policies and Guidelines
Current Bids & Proposals
SWaM and Non-SWaM Reporting
Vendor Feedback

SWaM Subcontractor Reporting

This form should be used by vendors to report their Small, Woman-owned and Minority-owned (SWaM) business spend.

Vendor *

Please enter the name of the COMPANY

Contract Number

Please enter the CONTRACT NUMBER

Name *

First

Last

Please enter the SUBMITTER'S first and last name

Email *

Please enter the SUBMITTER'S email address

Select Reporting Method *

Upload Spreadsheet/Document

Manual Input

Upload Document - Excel or Word only

Manually type information for each sub-contractor

ATTACHMENT 6
Proposal Submission Checklist
NOT REQUIRED TO BE INCLUDED IN PROPOSAL

It is important that the Offeror carefully read through the RFP and provide all required documentation. The proposal MUST be submitted and received on time to qualify for a chance at evaluation. Use this checklist as a guideline to ensure the proposal is complete before submission.

IMPORTANT DATES & REMINDERS

- No Questions Accepted after June 12, 2025, 2:00 p.m. All Questions must be directed toward the Procurement Officer for this solicitation: Kenneth Manahan, kmanaha2@umw.edu, and 540-654-1006.
- Proposal Due Date: July 3, 2025, no later than 2:00 p.m.- eVA will disallow any proposal uploads after 2:00 p.m., and therefore will not be accepted.
- Proposals shall be uploaded via the electronic online response function within the solicitation posting on the eVA Virginia Business Opportunities (VBO).
 - *If you run into issues submitting your proposal electronically through eVA, please contact eVA Customer Care at 1-866-289-7367.
- **Read the ENTIRE RFP including terms and conditions and attachments carefully before submitting a proposal.**

REQUIRED DOCUMENT SUBMISSION

Acknowledgement:

The classification of an entire proposal document, line-item prices and/or total proposal prices as proprietary or as a trade secret is not acceptable. If, after being given reasonable time, the Offeror refuses to withdraw an entire classification designation, the proposal will be rejected.

Documents to Submit:

- Completed and signed RFP cover page.
- Any/All signed addenda.
- Electronic Copy of Proposal (Original and Redacted)
- Completed Attachment 1, Single, Emergency and Administrative Point of Contact Identification Sheet.
- Completed Attachment 2, Contractor Data Sheet.
- Completed Attachment 3, Pricing Schedule.
- Completed Attachment 4, Small Business Subcontracting Plan.
- Current Certificate of Liability Insurance

UMW 2025 Commencement Main Stage Layout

Reduce page size to view document
80'-0"

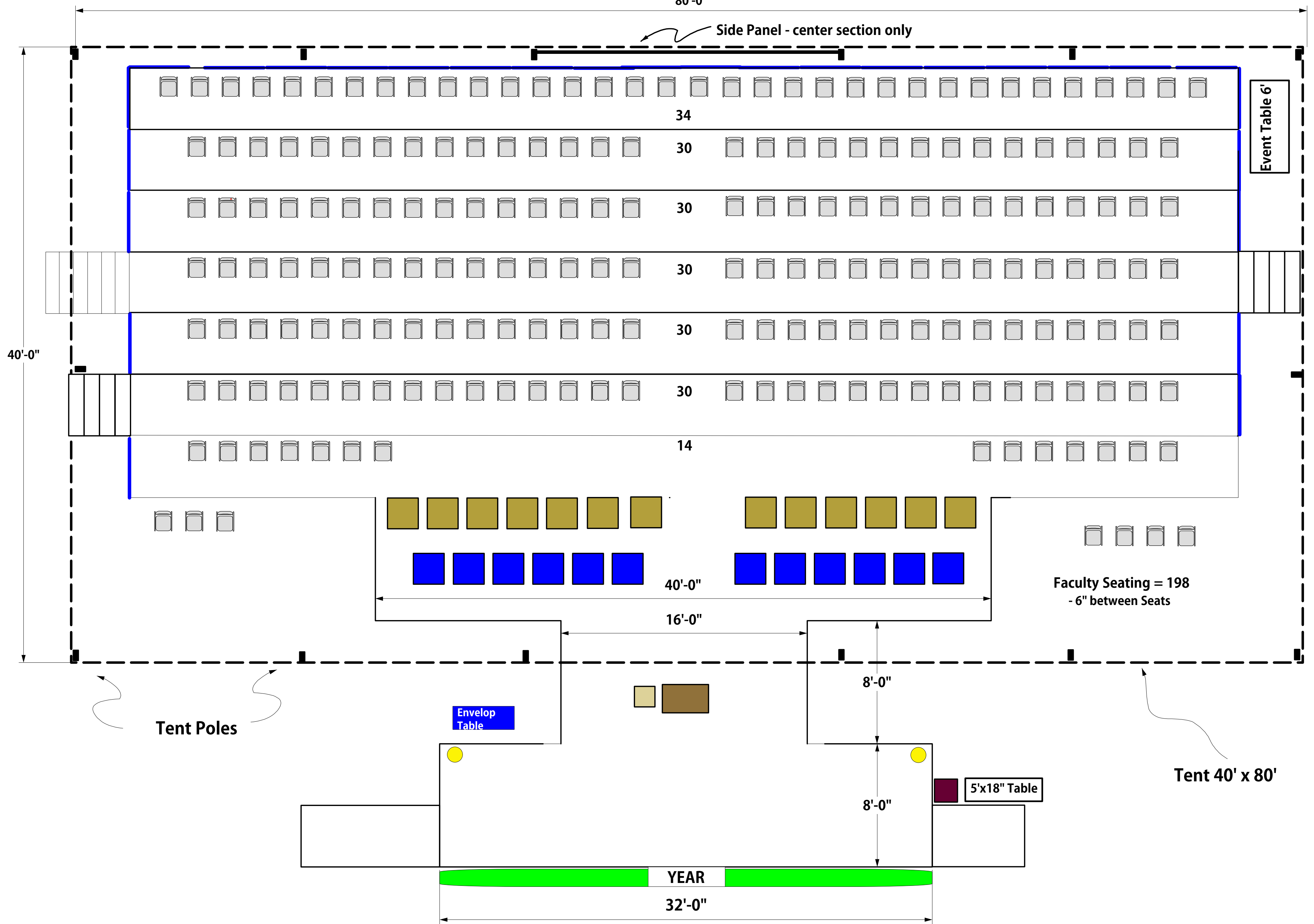

2025 VIP Tent

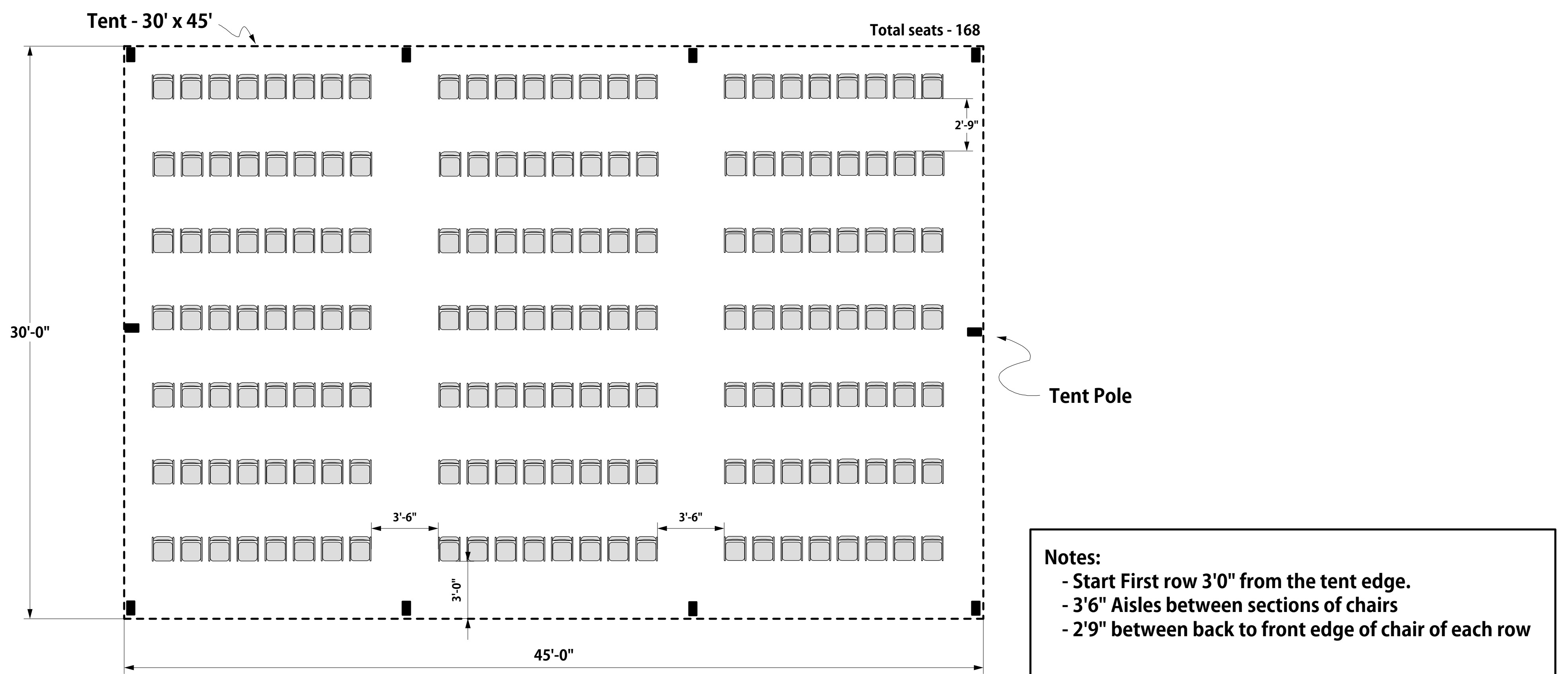

AV Tent/Tower

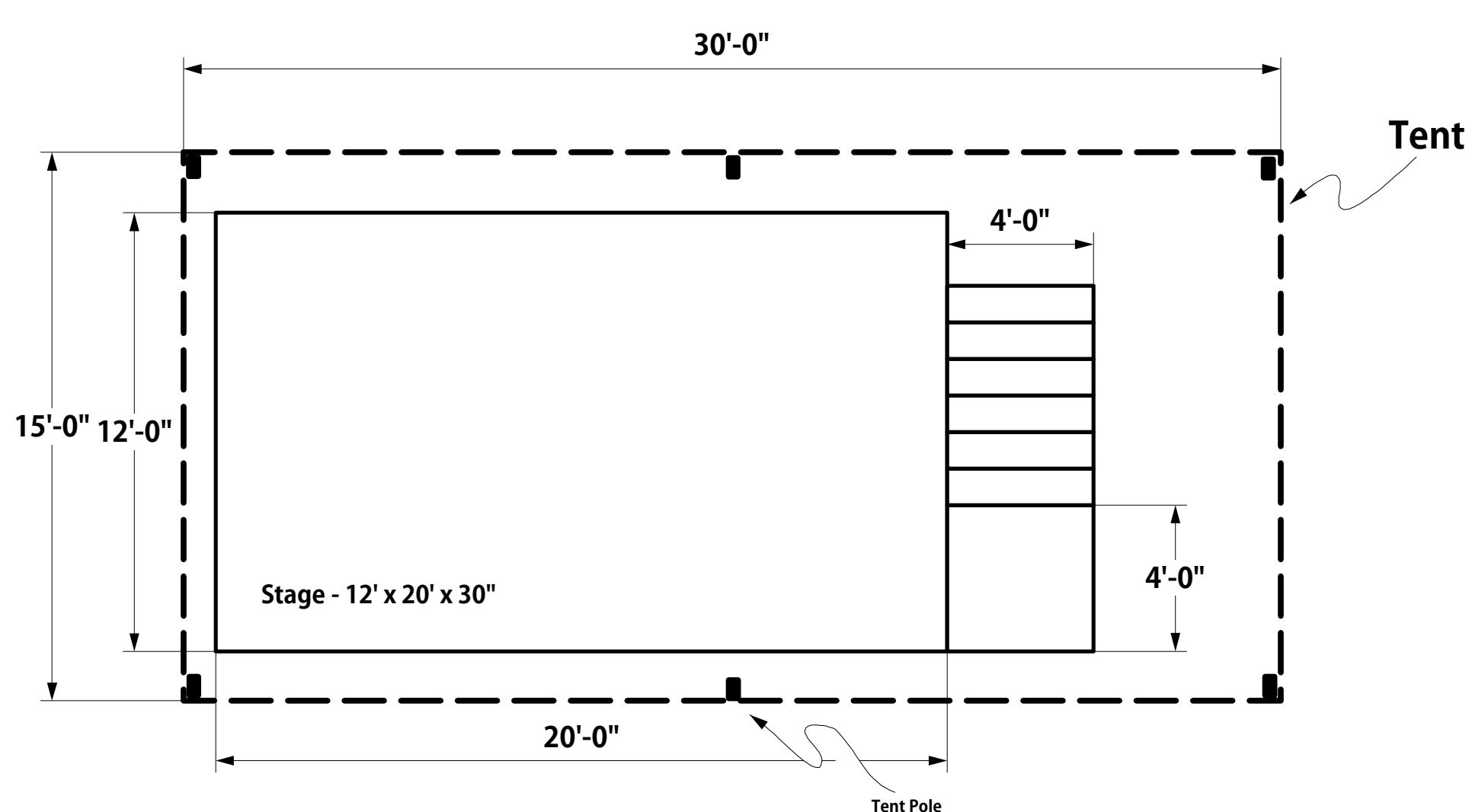

TENT and STAGE DETAILS BALL CIRCLE UNIVERSITY OF MARY WASHINGTON Drawn By: DOUGLAS E. NOBLE		Plate # 5
Revised Date: May 5, 2025	Scale: 1/4" = 1' - 0"	

July 15, 2025

Ampa Entertainment, Inc.
6701 Janway Road
Henrico, VA 23228

Subject: RFP #UCPUMW 25-1937 - Price Sheet Question
Reference: Ampa Entertainment, Inc. proposal dated June 26, 2025

Dear Mr. Rubis:

With reference to Ampa Entertainment's proposal dated June 26, 2025, submitted in response to the University of Mary Washington's solicitation #UCPUMW 25-1037, based on a review of the proposal the following is offered:

- The Pricing Schedule does not include a cost for Commencement Staging. Ampa is requested to review its proposal submission and, if the intent was to include pricing for Commencement Staging, you are asked to submit the proposed cost to the undersigned no later than 2:00 p.m., Thursday, July 17, 2025. Along with the pricing, please include a list of the items and assumptions on which the price is based.

Sincerely,

Kenneth R Manahan

Kenneth R. Manahan
Sr. Contract Officer



ampa events

6701 Janway Rd.
Henrico, VA 23228
804.358.5451
www.ampaevents.com

event services

planning
decorating
theme inventory
lounge furniture
designer bars
trade shows
centerpieces
site selection
destination services

stage production

av systems
show management
lighting
stage sets
rigging
touring

lighting & sfx

stage
decorative
architectural
display
confetti
rental & sales

pr/marketing

branding
product launch
product tours
pr events
grand openings

entertainment

arcade gaming
outdoor games
casinos
entertainers
music

rentals

event equipment
staging
furniture
party rentals

7/16/25

Ken Manahan
kmanaha2@umw.edu

Subject: University of Mary Washington Solicitation UCPUMW 25-1937

Dear Ken,

The Commencement Staging line item should read \$15,000 on Ampa Events' proposal that has been submitted. This will include the deck, two stairs, rails, and carpet. We estimate 366 total white folding chairs as needed on the RFP's floor plans.

Best,

Leslie Amason
Director of Sales
Ampa Events

"a direct source of unique inventory, technical & design services"

SEALED REQUEST FOR PROPOSAL (RFP)

ISSUE DATE: June 3, 2025
RFP NUMBER & TITLE: UCPUMW 25-1937, Special Event Equipment Rental
PROPOSAL DUE DATE & TIME: July 3, 2025, 2:00 p.m.
NOTE: Proposals received after the due date and time cannot be accepted.
PROPOSAL DELIVERY: Electronic file upload to eVA only
WORK LOCATION: [X] All Campuses [] Fredericksburg [] Stafford [] Dahlgren
COMMODITY CODE(S): 97741, 96234, 98172, 98143, 98136, 97732, 96260, 97735
PRE-PROPOSAL CONFERENCE: [X] Optional [] Mandatory [] N/A DATE & TIME: July 10, 2025 at 10:00 a.m.
PRE-PROPOSAL LOCATION: Eagle Village Executive Offices, Suite 480
1125 Emancipation Hwy., Fredericksburg, VA 22401
CONTRACT OFFICER: Kenneth Manahan EMAIL: kmanaha2@umw.edu
PERIOD OF CONTRACT: August 1, 2025 through July 31, 2026 with five, one-year renewal options that if exercised will extend the term of the contract through July 31, 2031.

In compliance with this Sealed Request for Proposal (RFP) and to all the conditions imposed therein, and hereby incorporated by reference, the undersigned firm offers and agrees to furnish the goods/services in accordance with attached signed proposal or as mutually agreed upon by subsequent negotiation. The undersigned firm hereby certifies that all information provided in response to this RFP is true, correct and complete.

By signing this proposal, you are certifying that you are an authorized representative of the offering firm and that the firm's principals or legal counsel have reviewed the Request for Proposal General Terms and Conditions and any Special Terms and Conditions. Any exceptions to the General or Special Terms and Conditions must be clearly identified in your proposal. No exceptions can be made to those General or Special Terms and Conditions that are mandated by law. If no exceptions are identified in your proposal, it is understood that the provisions will become a part of any final agreement.

THIS FORM MUST BE COMPLETED AND RETURNED WITH PROPOSAL

Name of Offering Firm: Ampa Entertainment, INC DBA Ampa Events
Address of Offering Firm: 6701 Janway Rd. Henrico VA, 23228
DSBSD Certification No.: SWAM 007285 Expiration Date: 1/18/2028
eVA ID: eVA-E84892 Tax ID: 54-1886661
Email: tedr@ampaevents.com Telephone: 804-358-5451
Website: www.ampaevents.com Fax:
Submitted By (Print Name & Title): Theodore C. Rubis President
Signature (In Ink): [Signature] Date: 6/24/2025

Dear Committee:

What's in a name? Some businesses just sprout up. True for Ampa also, but when it all started to develop in the 90's, much thought went into "What We Will Be?"

The Amphitheater in classical Greece was more than a place to enjoy comedy and tragedy. It was a place for communities, entertainment, thought, political and philosophical statements and a place to tell stories through drama. As the source of our name, it speaks to who we are at Ampa - a company that tells stories, drives messages, creates environments to drive a message, entertains and provide the production services and equipment for life's special moments. Ampa Events is a direct source for unique equipment, design and technical services.

For 29 years, Ampa Events has delivered excellence in the live event industry. This excellence started with our purposeful and thoughtful consideration of who and what we are as a company. Our longevity and success is perpetuated by: 1) Ampa's team - its knowledge, skills and drive; 2) the quality of Ampa's products - both inventory and services; 3) Ampa's ability to conceptualize events and communicate the approach, products and services clearly to our clients through business systems that provide itemized quotes and work orders; 4) Ampa's relevant experience as exemplified by a body of work spanning 21 years and various levels of complexity; and 5) methodology in performing the service - which starts with our focus on internal organization, policies and procedures and an incredible Customer Service Database Management system. These points shall be elaborated on while proceeding through the RFP response process.

To maintain this level of excellence, it is imperative that we employ great people. Ampa is committed to developing well paying jobs for career minded creative professionals. Jobs with living wages. We invest in recruiting on an ongoing basis to seek out the best and most talented college trained technical and artistic staff. Once we have found the right candidate, then we train the technician further, exposing them to the creative work we are called to execute and further advancing and molding their skills to apply effectively for live events. It is this level of commitment that is necessary to perpetuate our staffing needs for the future. With continued growth, Ampa is creating new positions to meet heightened demand.

Ampa's commitment to excellence is not limited to our people and the output of our fabulous scene shop. I am a student of business. A strong business structure is needed to keep it all running smoothly. Over 29 years, I have run a business that has thrived through several recessions without the need for layoffs. Ampa is a well financed business with superb business structure, procedures and support systems to perpetuate success for decades to come.

Through the following pages, I narrate Ampa's answers to each point in the RFP, inserted details examples and photos to illustrate our vast inventory and skill set. Ampa's skilled team, creativity, inventory, problem solving, years of experience, and close proximity to campus, and eVA SWaM business status is a winning combination for success.

Thank you for considering Ampa Events.

Sincerely,

Theodore C. Rubis
President, Ampa Events
6701 Janway Rd
Richmond, VA 23228

804-358-5451
www.ampaevents.com

General

What's in a Name?

Some businesses just sprout up. True for Ampa also, but when it all started to happen in the 90's, much thought went into What We Will Be?

Amphitheater, in classical Greece, is the embodiment of all production services for entertainment, thought, political and philosophical statements, a gathering place for communities. The association fit perfectly. Ampa, a complete source of production services and equipment for: all events, applied to support clients goals which may include a message, branding, heighten awareness of causes or just to have some fun.

History

For over **20** years, Ampa has played a role in life's most poignant moments. The first dance between a new husband and wife. Friends reuniting to share decades-old memories. A political hopeful launching a career. Colleagues uniting toward a shared mission. Volunteers raising money for a cause dear to their hearts.

Through it all, Ampa has relied on service as a cornerstone: working with you to pinpoint your needs and delivering.

Ted Rubis launched Ampa in 1985 as an entertainment-booking agency, building on his experiences with special events and his affinity for bringing people together. Responding to demand, Ampa began expanding its services. More importantly, it built a team of creative professionals who know how to use the resources at their disposal to serve your needs within your budget. Ampa can help you dazzle a large audience, bring crowds to their feet or discreetly fade into the background while those special moments emerge. It's up to you. As a Richmond-based company with team members in Tidewater and Washington, D.C., we're here to serve local, regional and national clients. Let us help you start celebrating, commemorating and bringing people together.

Ampa Events is a Richmond Base touring, design and event production services company, we're here to serve...

b. Identify the amount of sales your company has had (if any) during the last twelve months with each public Higher Education Institution within the Commonwealth of Virginia.

**Jan 2024 - June 2025**

Hampden Sydney College	\$106,342.95
Virginia Military Institute	\$ 46,807.00
University of Richmond	\$ 1,725.26
Va. Union University	\$ 1,100.00
University of Mary Washington	\$ 1,025.00
College of William & Mary	\$ 5,225.00
Randolph Macon College	\$ 2,694.00

c. Identify the location of your business indicating it is within 55-mile radius of UMW.



6701 Janway Rd
Henrico VA, 23228

Located on the North Side of Richmond, VA.

d. Provide documentation to substantiate proposed insurance is adequate to meet requirements of "Insurance" Special Term and Condition contained herein and to protect contractor's equipment from damage/destruction.



Ampa shall comply with, secure additional, and/or enhanced insurance policies in accordance with all specifications as needed. Axis Insurance Company has assured Ampa Events that all limits specified herein are attainable.

Vendors shall also comply or Ampa's policy will provide the university with the needed coverage.

[Ampa's Insurance on next page]

What we do

There are many event companies, meeting planners, a/v companies and lighting companies. What makes Ampa stand out is our focus on creativity along with the unification of all major event services under one roof. Ampa is not only creative in an artistic sense, but we are also creative in our approach to serving clients. Ampa's creative event design results in a maximization of our clients' budget, yielding the best bang for the buck. It is our extensive skill set as a company and our creative capabilities that gives us the ability to serve our clients in this manner. No matter what the budget, Ampa's creative approach to getting the job done and exceeding the client's expectations puts Ampa at the forefront in design and production for events and stage elements.

Insurance: Ampa is insured for all services with a \$2,000,000.00 liability policy. Additional Policy Binders are available as needed for high liability levels and work for the Federal Government.

Qualifications, Skills, Experience

Design & Fabrication	Prop & Stage Design	Directing
Carpentry	Artistry	Meeting Planning
Technical Building	Foam Carving	Scripting
Materials Analysis	Graphic Design	Technical Directors
Scenic Painting	Custom Gobo Design	Production Scheduling
Web Design	Color Study	Trade Show Services /
Hard Coat Technique	Wiring	Management
Drape	Auto Cad Design	Meeting & Event Directors
Seamstress	Renderings	Pre-production Services
Soft Goods	Auto Cad Design Shop	Technical Site Surveys
Vaccu-form	Audio/Visual	Concept Development
Lighting Design/Rigging		Event Management



Inventory

Ampa operates with over 30,000 square feet of time tested inventory which includes:

- | | | |
|---------------|-----------------|------------------|
| Stage Sets | Theme Decor | Lighting |
| Staging | Scenery | Lounge Furniture |
| Drape Systems | Support Systems | Designer Bars |
| Props | Audio Visual | Centerpieces |

Social Focus

Ampa supports Made in the USA, and Green Practices including Sourcing Locally. We create jobs in the Richmond area through the manufacture of our stage sets, props, scenery and other goods and services, here, on site, in our Western Henrico Distribution center and through our purchase of Made in the USA products including Furniture from North Carolina, lighting systems, electrical systems and more.

a-b. Provide understanding of "Requirement for Criminal Background Check of Personnel Assigned by Contractor to perform work on UMW Property" and "Drug Free Workplace" Special Term and Condition contained herein.

**Ampa shall comply with Special Terms and Conditions**

As a prerequisite to employment with Ampa Events, all employees are required to provide a criminal background check. Information on file at Ampa to be provided as needed.

Additionally, Ampa shall institute company wide drug testing starting in 2016.



CERTIFICATE OF LIABILITY INSURANCE

DATE (MM/DD/YYYY)

2/25/2025

THIS CERTIFICATE IS ISSUED AS A MATTER OF INFORMATION ONLY AND CONFERS NO RIGHTS UPON THE CERTIFICATE HOLDER. THIS CERTIFICATE DOES NOT AFFIRMATIVELY OR NEGATIVELY AMEND, EXTEND OR ALTER THE COVERAGE AFFORDED BY THE POLICIES BELOW. THIS CERTIFICATE OF INSURANCE DOES NOT CONSTITUTE A CONTRACT BETWEEN THE ISSUING INSURER(S), AUTHORIZED REPRESENTATIVE OR PRODUCER, AND THE CERTIFICATE HOLDER.

IMPORTANT: If the certificate holder is an ADDITIONAL INSURED, the policy(ies) must have ADDITIONAL INSURED provisions or be endorsed. If SUBROGATION IS WAIVED, subject to the terms and conditions of the policy, certain policies may require an endorsement. A statement on this certificate does not confer rights to the certificate holder in lieu of such endorsement(s).

PRODUCER Foundation Insurance Group Inc 3190 Fairview Park Dr. Ste 104 Falls Church VA 22042	CONTACT NAME: Certificate Department PHONE (A/C, No, Ext): 703-527-8780 E-MAIL ADDRESS: certificates@figva.com		FAX (A/C, No): 703-532-8300
	INSURER(S) AFFORDING COVERAGE		NAIC #
INSURED Ampa Entertainment Inc t/a Ampa Events 6701 Janway Road Henrico VA 23228	INSURER A : Axis Insurance Company		37273
	INSURER B : Accident Fund Insurance Co. of America		10166
	INSURER C :		
	INSURER D :		
	INSURER E :		

COVERAGES

CERTIFICATE NUMBER: 1072899902

REVISION NUMBER:

THIS IS TO CERTIFY THAT THE POLICIES OF INSURANCE LISTED BELOW HAVE BEEN ISSUED TO THE INSURED NAMED ABOVE FOR THE POLICY PERIOD INDICATED. NOTWITHSTANDING ANY REQUIREMENT, TERM OR CONDITION OF ANY CONTRACT OR OTHER DOCUMENT WITH RESPECT TO WHICH THIS CERTIFICATE MAY BE ISSUED OR MAY PERTAIN, THE INSURANCE AFFORDED BY THE POLICIES DESCRIBED HEREIN IS SUBJECT TO ALL THE TERMS, EXCLUSIONS AND CONDITIONS OF SUCH POLICIES. LIMITS SHOWN MAY HAVE BEEN REDUCED BY PAID CLAIMS.

INSR LTR	TYPE OF INSURANCE	ADDL INSD	SUBR WVD	POLICY NUMBER	POLICY EFF (MM/DD/YYYY)	POLICY EXP (MM/DD/YYYY)	LIMITS
A	<input checked="" type="checkbox"/> COMMERCIAL GENERAL LIABILITY <input type="checkbox"/> CLAIMS-MADE <input checked="" type="checkbox"/> OCCUR GEN'L AGGREGATE LIMIT APPLIES PER: <input checked="" type="checkbox"/> POLICY <input type="checkbox"/> PRO-JECT <input type="checkbox"/> LOC OTHER:			A1AMVA005-042895-15	2/28/2025	2/28/2026	EACH OCCURRENCE \$ 1,000,000 DAMAGE TO RENTED PREMISES (Ea occurrence) \$ 100,000 MED EXP (Any one person) \$ 5,000 PERSONAL & ADV INJURY \$ 1,000,000 GENERAL AGGREGATE \$ 2,000,000 PRODUCTS - COMP/OP AGG \$ 2,000,000 \$
A	<input checked="" type="checkbox"/> AUTOMOBILE LIABILITY <input checked="" type="checkbox"/> ANY AUTO <input type="checkbox"/> OWNED AUTOS ONLY <input type="checkbox"/> SCHEDULED AUTOS <input checked="" type="checkbox"/> HIRED AUTOS ONLY <input checked="" type="checkbox"/> NON-OWNED AUTOS ONLY			A1AMVA005-042895-15	2/28/2025	2/28/2026	COMBINED SINGLE LIMIT (Ea accident) \$ 1,000,000 BODILY INJURY (Per person) \$ BODILY INJURY (Per accident) \$ PROPERTY DAMAGE (Per accident) \$ \$
A	<input checked="" type="checkbox"/> UMBRELLA LIAB <input checked="" type="checkbox"/> OCCUR <input type="checkbox"/> EXCESS LIAB <input type="checkbox"/> CLAIMS-MADE DED <input checked="" type="checkbox"/> RETENTION \$ 0			A5AMVA005-042896-15	2/28/2025	2/28/2026	EACH OCCURRENCE \$ 1,000,000 AGGREGATE \$ 1,000,000 \$
B	WORKERS COMPENSATION AND EMPLOYERS' LIABILITY ANY PROPRIETOR/PARTNER/EXECUTIVE OFFICER/MEMBER EXCLUDED? (Mandatory in NH) If yes, describe under DESCRIPTION OF OPERATIONS below	Y/N	N/A	ARP12003382005	2/28/2025	2/28/2026	<input checked="" type="checkbox"/> PER STATUTE <input type="checkbox"/> OTHER E.L. EACH ACCIDENT \$ 1,000,000 E.L. DISEASE - EA EMPLOYEE \$ 1,000,000 E.L. DISEASE - POLICY LIMIT \$ 1,000,000
A	Equipment Floater			A1AMVA005-042895-15	2/28/2025	2/28/2026	Equipment \$100 Ded Comp \$1,000 Ded Coll 850,000 ACV
A	Hired Auto Physical Damage			A1AMVA005-042895-15	2/28/2025	2/28/2026	

DESCRIPTION OF OPERATIONS / LOCATIONS / VEHICLES (ACORD 101, Additional Remarks Schedule, may be attached if more space is required)

CERTIFICATE HOLDER**CANCELLATION**

For Information Purposes Only

SHOULD ANY OF THE ABOVE DESCRIBED POLICIES BE CANCELLED BEFORE THE EXPIRATION DATE THEREOF, NOTICE WILL BE DELIVERED IN ACCORDANCE WITH THE POLICY PROVISIONS.

AUTHORIZED REPRESENTATIVE

© 1988-2015 ACORD CORPORATION. All rights reserved.

ATTACHMENT 1
POINT OF CONTACT INFORMATION SINGLE POINT OF CONTACT
RETURN THIS FORM WITH YOUR PROPOSAL PACKAGE

PRIMARY POINT OF CONTACT

CONTACT PERSON'S NAME	Ted Rubis
CELL PHONE NUMBER	804-283-3090
IS CELL PHONE CAPABLE OF RECEIVING TEXT MSGS?	YES
BEEPER/PAGER NUMBER	
TELEPHONE NUMBER – NORMAL WORKING HOURS	804-359-5451
TELEPHONE NUMBER – AFTER WORKING HOURS	804-284-3090
FAX NUMBER	804-358-0572
EMAIL ADDRESS	tedr@ampaevents.com

EMERGENCY POINT OF CONTACT

CONTACT PERSON'S NAME	Leslie Amason
CELL PHONE NUMBER	804-901-1745
IS CELL PHONE CAPABLE OF RECEIVING TEXT MSGS?	YES
BEEPER/PAGER NUMBER	
TELEPHONE NUMBER – NORMAL WORKING HOURS	804-358-5451
TELEPHONE NUMBER – AFTER WORKING HOURS	804-901-1745
FAX NUMBER	
EMAIL ADDRESS	lesliea@ampaevents.com

(Attachment 1 Continued)

INVOICING/PAYMENT POINT OF CONTACT

CONTACT PERSON'S NAME	Sandy Crowe
CELL PHONE NUMBER	804-513-9047
IS CELL PHONE CAPABLE OF RECEIVING TEXT MSGS?	YES
BEEPER/PAGER NUMBER	
TELEPHONE NUMBER – NORMAL WORKING HOURS	804-513-9047
TELEPHONE NUMBER – AFTER WORKING HOURS	N/A
FAX NUMBER	
EMAIL ADDRESS	ampabooks@ampaevents.com

ATTACHMENT 1 -- STATE CORPORATION COMMISSION FORM

Virginia State Corporation Commission (SCC) Registration Information. The bidder:

X is a corporation or other business entity with the following SCC identification number 04991147 -
OR-

_____ is not a corporation, limited liability company, limited partnership, registered limited liability partnership, or business trust **-OR-**

_____ is an out-of-state business entity that does not regularly and continuously maintain as part of its ordinary and customary business any employees, agents, offices, facilities, or inventories in Virginia (not counting any employees or agents in Virginia who merely solicit orders that require acceptance outside Virginia before they become contracts, and not counting any incidental presence of the bidder in Virginia that is needed in order to assemble, maintain, and repair goods in accordance with the contracts by which such goods were sold and shipped in Virginia from bidder's out-of-state location) **-OR-**

_____ is an out-of-state business entity that is including with this bid an opinion of legal counsel which accurately and completely discloses the undersigned bidder's current contracts with Virginia and describes why those contracts do not constitute the transaction of business in Virginia within the meaning of § 13.1-757 or other similar provisions in Title 13.1 or 50 of the Code of Virginia.

***NOTE*>>** Initial in the following space if you have not completed any of the foregoing options but currently have pending before the SCC an application for authority to transact business in the Commonwealth of Virginia and wish to be considered for a waiver to allow you to submit the SCC identification number after the due date for bids (the Commonwealth reserves the right to determine in its sole discretion whether to allow such waiver): _____

RETURN THIS FORM WITH YOUR PROPOSAL PACKAGE

ATTACHMENT 2 CONTRACTOR DATA SHEET
RETURN THIS COMPLETED FORM WITH YOUR PROPOSAL PACKAGE

QUALIFICATION OF CONTRACTOR: The Contractor must have the capability and capacity in all respects to fully satisfy all of the contractual requirements.

11xYEARS IN BUSINESS: Indicate the length of time in business providing this type of service.

29 **Years** _____ **Months**

IIIxREFERENCES: Indicate below a list of at least four (4) recent references, either commercial or governmental, for which this type of service has been provided. Include the date the service was furnished, and the name and address of the person the University has permission to contact, date of service, value or order, and contract number:

Name & Address	Contact Person	Email Address	Telephone Number	Description of Work & Date Completed
Brooke Rentals	Jim Brooke	jcb@brookerental.com	704-938-4807	
Vogue Flowers	Paul Christophakis	paulc@vogueflowers.com	804-353-9600	
Corcoran Caterers	Leslie Grimes	leslie@corcorancaterers.com	301-588-9200	
VMI	Command Master Sergeant Rubinstein	rubensteinsd@vmi.edu	540-464-7325	

- a. Describe your understanding and any experience with temporary structure permits through the Commonwealth of Virginia, Bureau of Capital Outlay Management.



Ampa shall facilitate the permitting process for county/city permits, such as building, fire, staging, etc. and provide safety packages that are required for all permitted tents and structures per locality requirements.

For additional information that illustrates the extent of our support for an event, please review the below Maryland Tourism Event.

UNIQUE STRUCTURES - Maryland Tourism Marketing Event

We love outdoor events. Nothing like a spring or fall day outside for a worthy cause or business goal. Maryland Tourism retained Ampa to design marketing solutions to "sell" International Travel Planners on Maryland as a destination at the IPW, the US Travel Associations premier event. This event is the perfect discussion of Form and Function delivered by Ampa. The designs must be attractive and affective in an advertising sense, but also must work in the potential most hostile environment for an outdoor event - an open space on the waterfront. Ampa's design team is collegiately trained with a good general understanding of structural design as taught in university theater programs. Ted Rubis, the owner of Ampa, took many physics and structural classes in undergrad - a sort of hobby. Combined, our team provided technical drawings to a qualified engineering firm for final approval and a Seal for the State of Maryland Building Code to validate the designs for building inspectors in advance of installation.

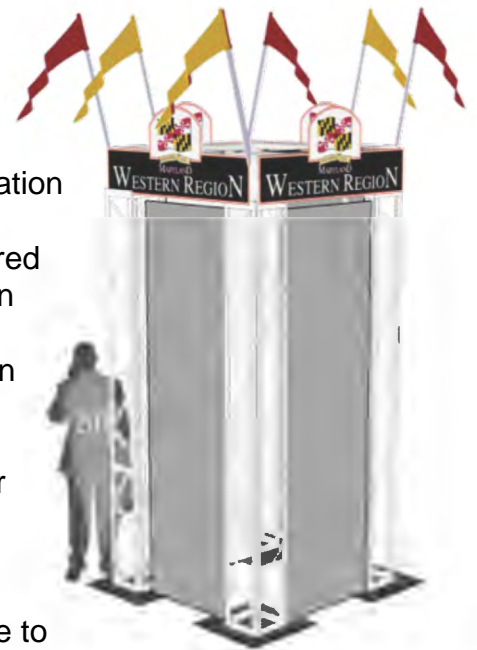

TRADITIONAL STRUCTURES

Also included here are photos of tented structures installed for various clients. (Roanoke College Capital Campaign, Richmond Children's Hospital lit for show conditions) Tents are a simple project. First we listened to the clients carefully to gain an understanding of the "big picture" and goals for the event. Then we conduct a site inspection and consider site factors for recommendations and installation. There are many practical matters to consider prior to install that affect functionality on site. Then we make a recommendation.

Tents are submitted to local building inspectors for permits and pre-approval and then site walkthroughs with inspectors are scheduled as needed.



Roanoke College Capital Kickoff

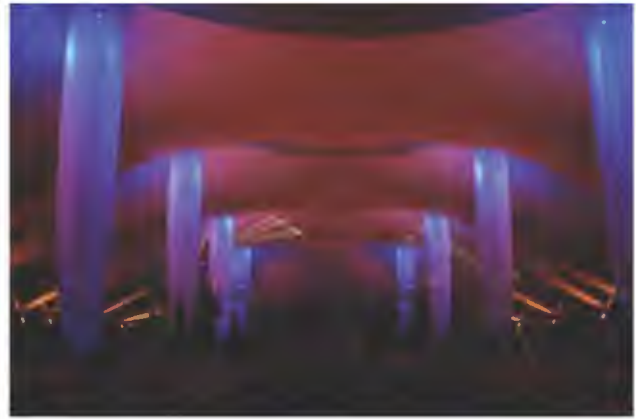

University of VA Family Weekend



Nace Gala



Children's Hospital Gala

b. Identify your proposed single point of contact, emergency point of contact and business (invoicing) point of contact (reference attachment 2) for all UMW special event rental services.

**Single Point of Contact:**

Theodore Rubis - President
Phone # - 804-358-5451
Cell Phone # - 804-283-3090
Fax # - 804-358-0572
Email - ted@ampaevents.com

Administrative Point of Contact:

Leslie Amason Director of Sales
Phone # - 804-358-5451
Cell Phone # - 804-901-1745
Fax # - 804-358-0572
Email - lesliea@ampaevents.com

Emergency Point of Contact:

Leslie Amason Director of Sales
Phone # - 804-358-5451
Cell Phone # - 804-901-1745
Fax # - 804-358-0572
Email - lesliea@ampaevents.com

Invoicing/Payment Point of Contact:

Sandy Crowe - Bookkeeper
Phone # - 804-358-5451
Cell Phone # - 804-513-9047
Fax # - 804-358-0572
Email - books@ampaevents.com

c. Provide three references for contracts with similar size, scope, capabilities. Include the contract number, the agency name, the point of contact (Contracts and/or actual Customer), phone number, and email address, along with date of service and value of the order (reference Attachment 3, Contractor Data Sheet).



1. Virginia Military Institute - Command Master Sergeant Rubenstein-
rubensteinsd@vmi.edu - 540-464-7325 Job#14219 - 3/8/24 - Budget \$20,012.50

2. Hampden Sydney College - Cameron Cary - ccary@hsc.edu - 434-223-6000 -
Job #14461 - 10/25/24 - Budget \$106,342.95

3. College of William & Mary - Laura Talbot - lmtalbot@wm.edu - 757-221-1184
-Job #14800 - 6/6/25 - Budget \$5,225

d. Identify your direct experience and expertise in convention, event, or hospitality industry.

There are many good production companies with great technical skills, people and deep pockets for the latest in high tech AV equipment. This is part of UMW's need. Creativity is the other half of the equation. But, even here, there is much to consider.

For 29 years, Ampa Events has creatively provided solutions for client needs. Yes, creative can be defined as artistic. And, yes, we are artistic. But it is the creative minds that are best suited for complex productions and problem solving. It is the creative minds at Ampa that will provide the true lifting and toting for the event.

Ampa sells itself as "a direct source of unique inventory, technical and design services." Yes, we have huge inventories in house, however, we will call on other SWAM vendors and tap our long standing relationships with expert companies in other areas such as High Def LED Screens for indoor installation and outdoor use via trailered units.

e. Describe ability to provide special event rental services for small or large, multi-location events. Be specific in detailing the event from beginning to end including ability to provide set-up and take-down services.



Ampa's ability to provide special event rental services, is clearly documented in over 29 years of successful and profitable business operations. Our body of work is published in our website which chronicles work for small and large projects including, rental pickup, rental drop-off, rental with complete installation, and the complete design and execution of complex projects. Also posted, find specialty technical services for large and small projects including audio visual, sound & lighting , specialty installation, and finally also documented is a history of creative solutions for clients of all types.



Rental and Technical Services

Example of providing special event rental services.

Ampa was hired by Corcoran Caterers to convert a construction zone in a Reston, VA cloud storage facility into a well decorated VIP reception for executive guests and public officials. In the before and after pictures you will see rental equipment services, general installation services, technical installation services including illumination lighting, decorative lighting and AV services, design and decorating services, and more. During the build up to execution Ampa provided site survey and assessment services, technical and decorative design services.

General event management which included interaction with facilities, personnel, timeline management and a level of professional is result in the smooth execution of a highly complicated project.

Beginning to end service provided

This example included installation planning 6 months in advance. Ampa communicated weekly with the construction foreman for updates on construction schedule and times for site inspection. Onsite planning then took place with building managers, construction representatives, the end client, and Corcoran Caterers. Ampa was the catalyst for moving the projects forward the 6 months period prior to the production. During completion of construction Ampa provided timelines and updated these timelines regularly. The timelines were paramount in organizing and notifying all key numbers involved in the execution giving everyone a clear understanding of what was to be done and at what time. These timelines included fabrication schedules for custom components ordered by the client to be completed in a timely manner by Ampa's scene shop as well as warehouse and personnel schedules for employees to load trucks and depart for installation.



Installation began the day before the event date. Ampa dispatched a crew of 8 including the president of the company who was the account manager and designer for the project, 2 carpenters, 2 lighting/AV technicians, and several university trained theater technicians. Installation was completed in an 8 hour period for client to review before close of business. Technicians remained on site for operation and management of production during the event day. The event started at 6:00pm and concluded at 9:00pm.

Guest enjoyed themselves so much that the event continued for an additional hour. Ampa's 24ft box truck arrived at 8:00pm according to preplanned schedule with technical crew for takedown and removal and offsite in 3 hours with a crew of 6. Post-Event the equipment was unloaded, checked individually and returned to stock. Ampa's return to stock system includes a thorough evaluation of equipment to note of any repairs are necessary prior to renting. Additionally, Post-Event Ampa calls all clients for a review of a the program in a customer service survey.

f. Describe in detail warranty given on all equipment and service.



Ampa's designs are 100% itemized and thus provide for a 100% itemized shipping bill of lading. Should a product be delivered or not operate as designated the equipment cost shall be refunded.

g. Identify any certifications and licenses that you the contractor and/or employee(s) may currently hold.



Certified Rigging

h. Describe the training, expertise, and supervision of personnel employed by the contractor that will be assigned to service this contract.



Question answered in our company Resume pg. 19

j. Provide resumes of key personnel that will be assigned to this tasking.

[Ampa's Resumes on next page]

Our Core Team - Bios

Theodore Rubis - President of Ampa Events

When Ted was working his way through pharmacy school at VCU-MCV, he never imagined that the entertainment business he launched as a side project would become a full-time passion.

A native of Richmond, Ted dove into studies at Virginia Tech and graduated from the VCU/MCV School of Pharmacy, returning to school later to focus on business, economics, finance and accounting.

Throughout his career, Ted found himself being called upon by organizations to help with creative projects. Along the way, he studied stage craft as a hobby. As a young professional he worked on a number of charity events to raise money for the Virginia Museum of Fine Arts. Looking back, he can see how his academics and leadership pursuits all came together in building a creative, successful and thriving event company -- and a talented team to carry out Ampa's mission.

With over 25 years of creative projects under his belt, Ted has honed his skills in design, showmanship, decorating, lighting and professional event management. He describes himself as a technical production manager, but his creativity and knowledge takes him far beyond as a designer and senior producer. He will tell you that adding value to client events through Ampa's creativity and driving messages with production services is the "fun" that keeps him going.

He may no longer be helping patients at the pharmacy counter, but after more than 25 years, Ted's perfected a different kind of chemistry -- one that creates lasting memories and unforgettable moments for clients from all walks of life.

Stephanie Rubis - Vice President & Corporate Attorney

Stephanie provides crucial services to Ampa in the review of contracts, employee relations, human resources and, in general, management of Ampa Events. As a corporate lawyer during the first half of her career and later a prosecutor, Stephanie guides Ampa in all contract and legal matters.

Sandy Crowe - Bookkeeper

Sandy has been with Ampa Events since December 2012 as an office Manager/Bookkeeper as well as Payroll Manager. She lives in the country in Charles City County with her gardening husband. Below is her skillset:

- 35+ years of office-related experience in a variety of atmospheres with consistently increasing responsibilities in areas of management.
- Accounts Payable/Accounts Receivable, Billing Invoicing, Producing purchase order and other bookkeeping experience PeachTree and Quickbooks programs
- "Hands-on" experience in all areas of office operations to include word processing, processing of forms development, phone duties, office manager, company representative in professional social activities.
- Attended – J. Sargeant Reynolds Community College, VA –Accounting and Management Courses
- Attended - Camden County College, Camden, NJ - -Business Degree Courses

Leslie Amason - Director of Sales & Senior Event Designer

For over 30 years, Leslie has produced special events for corporate, non-profit organizations, and PGA tournament events. Though her BA degree is in the world of fashion, she decided after college that her creative passion was with the event industry. Her dedication and obsession for detail to each event shows through her expertise in every event. Leslie's unique southern personality has a way of connecting with each client and has won the hearts of many.

James Meekins III - Graphic Designer

James has a BFA in Graphic Design from VCU. He has used his foundation in art to create designs for events and internally. He has been a key player in our marketing and creative schemes. He also brings in a vast experience in the print and web industry. His support in presentations and designs and his natural skills as a photographer, writer and artist are invaluable to our needs and that of our clients.

Other Skilled and Experienced Theater Technicians drawn from VCU, Richmond Ballet and other local Theaters as overhire as needed.

- a. Provide a internet address for your firm's online special event rental catalog, if available, or promotional material that provides photographs, descriptions, quantities available and pricing for offered items.



www.ampaevents.com

<http://www.ampaevents.com/party-rentals>

- b. Describe seating options including the maximum number of uniform chairs that can be accommodated with one order. Include seating specifications, colors, etc. Provide descriptive literature, specifications and pictures of seating options being offered.

As seen in photos below of VA Highway Safety Memorial Dedication and a political event at the capitol, Bulk Chairs are available in White, Black, Gray and Brown (resin and metal frame) We do not own these chairs, but prove subcontracts at Market Costs with no mark up. Over 10,000 are available.



- c. Describe staging options to include various sizes, styles, skirting, etc. Provide descriptive literature, specifications, and pictures of staging being offered.

Standard Stage Deck - Wood & Carpeted



**4x4ft Stage Decking
wood
carpeted**

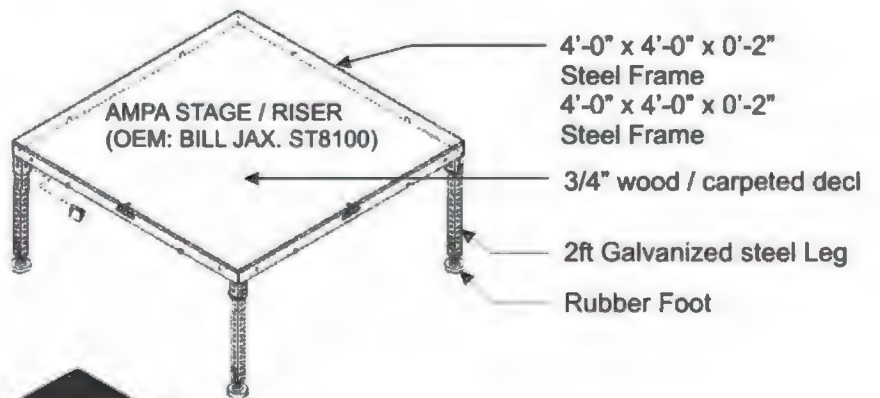

**2x4ft Stage Decking
(wood)**



d. Describe table options to include various sizes and styles. Provide descriptive literature, specifications and pictures of tables being offered.

Standard Tables



4',5' & 6' Round Tables



Cocktail High 42" w/ Metal Stem



Cocktail Low 30" w/ Metal Stem



Rectangle Tables 6' x 24"



Rectangle Tables 8' x 24"



Serpentine 5' Tables

Farm Tables



French Country Dining Table
6' x 30" x 40"



Java Dining Table
6' x 30" x 36"
Mahogany or Natural



Lit Stage Deck



Lit Stage or Dance Floor 4'x4' Section w/ LED - 4'w x 2'h x 4'd

Lit ¼ Circle Stage or Dance Floor 4'x4' Section w/ LED - 4'w x 2'h x 4'd

Stage Rails, 4' Section

Stage Rails, 8' Sect

Stage Stairs, Wood 2'



Acrylic Tables

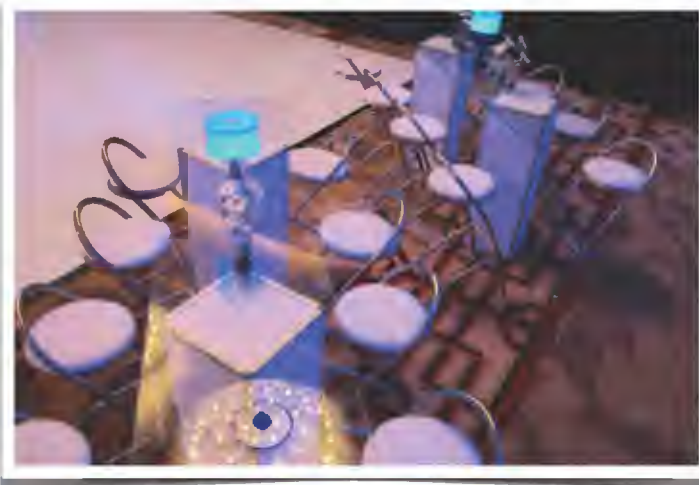

Acrylic Communal Table, High
96" x 42" x 24"



Acrylic Dinner Table, Low
48" x 30" x 96"



Acrylic Dinner Table, High
48" x 42" x 96"



Acrylic Square Table, Low
48" x 30" x 48"



Acrylic Dinner Table, Low
48" x 30" x 96"



Acrylic Square Table, High
48" x 42" x 48"

- e. Describe tent options to include various sizes and styles and associated cost. Provide descriptive literature, specifications and pictures of tents being offered.

Tents



10' x 10' Frame-Type Tent = \$140



15' x 15' Frame-Type Tent = \$299
 15' x 30' Frame-Type Tent = \$425
 15' x 45' Frame-Type Tent = \$525



10' x 20' Frame-Type Tent = \$295



20' x 20' Frame-Type Tent = \$380



10' x 30' Frame-Type Tent = \$410
 10' x 40' Frame-Type Tent = \$520
 10' x 50' Frame-Type Tent = \$635



20' x 30' Frame-Type Tent = \$520

Tents



30' x 60' Frame-Type Tent = \$1,160

- 20' x 40' Frame-Type Tent = \$635
- 20' x 50' Frame-Type Tent = \$755
- 20' x 60' Frame-Type Tent = \$870
- 20' x 70' Frame-Type Tent = \$985



40' x 100' Push Pole-Type Tent = \$2,200



30' x 30' Frame-Type Tent = \$780

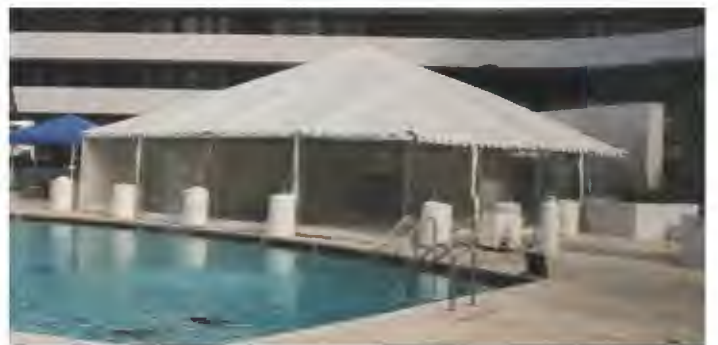

40' x 40' Frame-Type Tent = \$1,350



30' x 40' Frame-Type Tent = \$920

Tents



40' x 40' Push Pole-Type Tent = \$2,200



40' x 60' Push Pole-Type Tent = \$1,860



40' x 60' Frame-Type Tent = \$1,730
40' x 80' Frame-Type Tent = \$1,970



40' x 80' Push Pole-Type Tent = \$1,990



40' x 80' Push Pole-Type Tent = \$2,070



40' x 60' High Peak Push Pole-Type Tent = \$1,760



60' x 100' Push Pole-Type Tent = \$3,465

Tents



60' x 120' Push Pole-Type Tent = \$3,935
 60' x 140' Push Pole-Type Tent = \$4,410
 60' x 160' Push Pole-Type Tent = \$5,030

60' x 60' Push Pole-Type Tent = \$2,675

Tent Accessories



60' x 60' Push Pole-Type Tent = \$2,675

60' x 60' Push Pole-Type Tent = \$2,675
 Artificial Turf per sq. ft. = \$0.40
 Double Glass French Doors = \$260



Pedestal Fan = \$38

Tent Accessories



Entrance Marquee = \$140



Sateen Pole Covers - each = \$15



Flexible Marquee 7'x7' / section = \$140
 Globe Lights String (8) = \$80
 Miniature Bulb String = \$80
 Outdoor Flooring - Tents or walkways per sq. ft. = \$1.15



Sateen Pole Drapes - each = \$28



Sateen Tent Liner - Call for Price



Picket Fence Panel - 72" x 42" = \$24

Tent Accessories



Sidewalls - Clear per 20' section



Tent Heater 170M BTU



Sidewalls - Solid White per 20' section



Tent Heater 52,000 BTU - Electric 220V



Sidewalls - Window per 20' section
Street Lights - 4 globes



Tent Heater 90M BTU
Uplighting (Par Cans) per 300w light
White 4-light Chandelier



Tent Furnace 400,000 BTU - Indirect propane heat with ductwork (propane is additional)



- f. Describe portable sanitation unit options to include various sizes and styles and associated cost. Provide descriptive literature, specifications, and pictures of comfort stations being offered.

Ampa shall partner with a VA Small or Minority owned business to provide portable toilet. Product will be passed on to client at Cost with No Mark Up.

- g. Describe portable generator options to include various sizes and power capabilities. Provide descriptive literature, specifications, and pictures of generators being offered.

***Delivery and Environmental fees are not included**



Portable Generator, 6.5-6.9 kW



Portable Generator, 9.6-9.9 kW



Generator, 19-29 KVA

h. Provide information on other items your firm provides for special event rental.

FURNITURE & BARS

Sofas
Chairs
Barstools
Tables
Charging Stations & Tables
Benches & Ottomans
Bars
Bar Accessories
Pillows

DECOR BY THEME

1920s Gatsby Roaring 20's
1950s
1960s
1970s
1980s
007
African
Alice in Wonderland
American Diner
Arabian
Awards
Back to the Future
Backdrops
Bar Hire
Bavarian
Baywatch
Beach & Buffet
Beauty & the Beast
Big City
Black & White
Bollywood
British
Burlesque
Caribbean
Carnival
Carpet Walkways
Casino
Celebrations
Charlie and the Chocolate
Factory
Christmas
Christmas - All Theme Ideas

Christmas - Christmas Market
Christmas - Contemporary
Christmas - Rustic
Christmas - Santa's Grotto
Christmas - Traditional (Red,
Gold & Green)
Christmas - Victorian
Cinderella
Cinema
Circus
Cirque Du Soleil
Classical
Come Dancing
Cruise
Cuban
Theme Casino
Fairground
Fairytale
Farm
Farm-To-Table
Festival
Fiesta
Fishing
Football
Fourth of July
Food and Drink
Football
Frames
Frozen
Game Show
Games
Gangsters
Garden
Gentlemens Club
Giant Make-Believe
Gold
Grand Prix
Grease
Greek
Halloween
Heaven
Hell
Hollywood
Horse Racing

Hunting
Illuminated
India
Industrial
Industrial Chic, Vintage
International
Italian
Jungle
Las Vegas
Life-Size Figures
London
Mardi Gras
Medieval
Mid-Century Modern
Military
Moroccan
Musical Instruments
Narnia
Nautical
Neon
New Orleans
New Years Eve
New York
Night at the Museum
Night Club
North Pole
Oktoberfest
Old Hollywood
Olympics
Oriental
Outdoor
Oversized
Paris
Parisian Burlesque
Park
Peter Pan
Pirate
Police
Prehistoric

Pub
 Racing
 Regency
 Rock & Roll
 Rodeo Rio
 Roman
 Royal
 Safari & Lost City
 Seaside
 Scenery
 School
 Secret Agent
 Seven Deadly Sins
 Shabby Chic
 Sherlock Holmes
 Ski Lodge
 Soft Furnishings
 Space & Sci-Fi
 Space
 Spandex
 Spanish
 Sports & Tailgate
 Speakeasy
 Star Wars
 Steam Punk
 Storybook
 Street Festival & Food Trucks
 Superheroes
 Sweet Treats
 Television & Film
 Tiki
 Titanic
 Toga Party
 Toyland
 Transportation
 Travel - Modern
 Travel - Vintage
 Trees
 Trees, Plants & Foliage
 Tropical
 Under The Sea
 Urban / Street
 Venetian
 Victorian
 Wartime

Washington & Patriotic
 Western Tex-Mex
 White Party
 Winery
 Winter Wonderland
 Wizard of Oz
 Wizard School
 Woodstock
 Zen

STAGE SETS

Hard Sets & Drape Kits
 Contemporary Sets

PARTY RENTALS

Chairs
 Tables
 Stage & Dance Floor
 Rope, Stanchion & Carpet
 Linens
 Chargers, China & Flatware
 Glassware
 Charging Stations & Tables
 Novelty Food
 Arches, Columns & Umbrellas

CENTERPIECES

Floral
 Lanterns, Candles, &
 Candelabra
 Light Up & Prop
 Silks
 Urns & Containers
 Retail

LIGHTING & AV

Conventional
 Intelligent
 LED
 Special Effects & Confetti
 Support Gear, Controllers,
 Truss
 String Lights, Lanterns,
 Chandeliers
 Gobos

Audio Visual & Podiums
 For Sale

ACCESSORIES

Columns, Pedestals & Lamp
 Posts
 Screens
 Foliage
 Urns & Containers
 Charging Stations & Tables
 Umbrellas

ENTRANCES

PERGOLAS & TRELIS

STATUES & PROPS

Statues & Sculptures
 Cutouts
 Props
 Signs & Letters

DRAPE

Fabrics
 Kits

FLAGS & BUNTING

WEDDING DECOR

Service Sets, Pergolas &
 Trellises

Drape

Weddings Chandeliers &
 String Lights

Gobos

Wedding Collections - Pure
 White
 Wedding Collections - Rustic

GAMES

Arcade & Table Games
 Carnival & Other Games
 Inflatables & Rock Wall
 Casino

Reference website for additional products and services: www.ampaevents.com/party-rentals



Mahogany Cocktail High with
Pedestal
24" x 42" x 24"



Mahogany Communal Table with
Pedestal Legs
96" x 42" x 24"



South Seas Pub Table
36" x 42" x 36"



Farm Tables & Communal Tables



Knotty Pine Dining Tables have multiple leg options



Hand Buffed Rich Chestnut Stained Knotty Pine



Knotty Pine Dining Table with Metal Legs
96" x 30" x 40"



Knotty Pine Dining Table with Spindle Legs
96" x 30" x 40"



Knotty Pine Dining Table with White Spindle Legs
96" x 30" x 40"



Butcher Block Communal Table w/ Chestnut Stain
96" x 30" x 24"
96" x 42" x 24"



Butcher Block Cafe Table w/ Chestnut Stain
24" x 30" x 24"



Butcher Block Cocktail High Table w/ Chestnut Stain
24" x 42" x 24"

Stage Skirting & Accessories



- Box Pleat Stage Skirt 1' Black - 12'w x 1'h = \$20
- Box Pleat Stage Skirt 2' Black - 12'w x 1'h = \$25
- Box Pleat Stage Skirt 3' Black - 12'w x 1'h = \$25
- Box Pleat Stage Skirt 4' Black - 12'w x 1'h = \$45

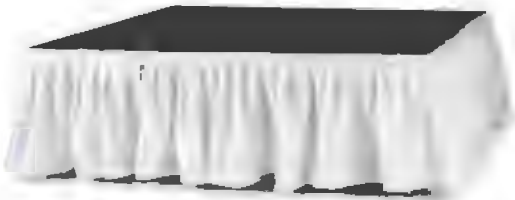

- Box Pleat Stage Skirt 2' White - 12'w x 1'h = \$45



- Stage Stairs - 42"w x 24"h x 42"d = \$125
- Wooden Stage Stairs 2' - 48" x 24" x 24" = \$25.00



- Stage Deck, Cross Bracing - 48"w x 42"h = \$2.50

Stage Rails, 4' Section = \$25

Stage Rails, 8' Section = \$35

Stage Stairs, Wood 2' = \$20

Curved Stage Deck



Left Curve Stage Deck
4'x2' - \$65





Right Curve Stage Deck
4'x2' - \$65



1/4 Circle Stage Deck
4'x4' - \$65

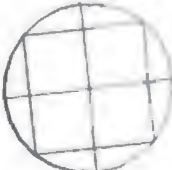
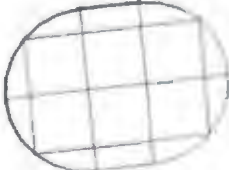

				Delivered & Install		
		Wood Deck	Carpet Deck	Lit Deck		
1.	 8 x 8ft Round Stage w/ Black Skirting	\$675	\$775	Call For Price		
2.	 12 x 12ft Round Stage w/ Black Skirting	\$975	\$1175	Call For Price		
3.	 12 x 16ft Round Stage w/ Black Skirting	\$1775	\$1975	Call For Price		
4.	 16 x 16ft Round Stage w/ Black Skirting	\$2175	\$2375	Call For Price		

- a. Describe timeframe for set-up and take-down of equipment.



Timeframe for setup and take down is specific to the equipment as well as the venue and loading conditions these and other variables are carefully considered when an account manager is estimating labor requirement for each production.

Labor requirements are determined by the natural flow of the event. Firstly, a driver is required, secondly the venue and loading circumstances are evaluated, thirdly the requirements of installations are evaluated. Venues may provide a 2hr install period thus requiring more labor and installation. Finally, ampa evaluates the specific equipment and the skill level of labor required to install specific equipment.

Ampa's goal is a scientific approach for all process in business for over 2 decades during our second decade we began studying and collecting information on the required to install various products in our inventory. In our digital database there is a field that indicates the amount of time required to install a 12x12ft square designer bar (2 carpenters = 1.5hrs) The same is true for stage sets and commodity equipment such as tables and chairs. All processes at ampa are design accurate estimating and execution for great customer service.

- b. Describe consultation and guidance that may be provided to UMW in determining exact needs for specific events and locations. Describe ability to accommodate requests for site visits to make recommendations and suggestions concerning equipment needed.



Ampa Skill may be applied as follows:

1. Stage Craft and Design Service

The complete development of a stage design. From concept development, to hand drawings, renderings and an end product with appropriate engineering stamps ready for approval by the committee.

2. Fabrication Services

Our full service theater style scene ship is capable of fabrication in standard and unique materials. Integrating AV services in the stage design and general functionality of the flow of persons on and off stage plus accommodations for technical need are what a Thinking Company does naturally. We are a thinking company with a full understanding of production services and run of show.

3. Technical Site Evaluation

Drawing on over 20 years of experience building projects from the parking lot up, the committee will find our technical knowledge extremely valuable. This is a knowledge base across all disciplines.

c. Describe in detail cancellation requirements.



30 Days cancellation notice preferred. Special conditions may be negotiated with each contract.

Weather policy: Outdoor events and the weather are the complete responsibility of the client. ampa reserves equip personnel and support services specifically for each project in advance thus earning the majority of our fee during the advance planning design period of production design services.

d. Describe invoicing procedure and timelines. Provide sample invoice with proposal.



Ampa shall track all aspects of the production via QuickBooks Accounting software under the watchful eyes of our veteran bookkeeper, Sand Crowe. Quickbooks shall generate all desired consolidate accounting services, and post event reports. All invoices shall accompany paperwork. Bookkeeper is available as needed.

1. General Event Design Production Service Standard Procedure:
 - a. 50% deposit up front
 - b. Final Payment due upon arrival
2. Custom Fabrication Invoicing Procedure:
 - a. 50% deposit up front
 - b. Final Payment due upon arrival

Ampa is happy to accommodate UMW Procurement needs.

- e. Unanticipated events may be held with little to no notice. Describe the expected turnaround time for events at UMW and how tight deadlines are met.



Some of the most extreme cases with quick turnaround times are every 4 years during Inaugurals. Routinely operatives from both parties call Ampa with less than a week's notice for patriotic, decor for stage backdrops for general use. All of which must be quickly uploaded for invoicing and fast contract turnaround to allow for individual truck loading and scheduling of personnel while we prefer more notice several events were planned in 2016 with less than 24hr notice. One event in particular had there production a day away had our company on file and didn't let us know until 11pm at night for a 6am departure (thats 7hrs later). Upon receipt of the call Ted activated production staff to immediately open the warehouse and load trucks for departure for 6am install. Ampa has a unique advantage in servicing short notice programs in the depth and breath of our inventory as well as through our online eCommerce ordering system. Quick orders may be placed by rentals website with contract turnaround in 24hrs upon receipt of contract, trucks are loaded and personnel are scheduled.

- f. Provide any documented standard operating procedures that would mitigate risk to UMW.



Ampa shall provide 100% itemized proposals with complete equipment lists and designs; itemized entertainment, parking and other services as requested by client.

1. Our Database is an itemized sales system.
2. Our Database creates a pick list.
3. Inventory is pulled to holding bays and checked by manager.
4. The Order is then loaded on truck.
5. Managers check truck for accuracy of the order.

*10% additional equipment is provided along with additional general support gear.

- g. Describe your staffing plan for delivery, set-up, operation, take-down and removal of equipment (numbers of employees, types of employees, responsibilities of employees).



Example of Staffing Plan: VMI MidWinter Dance

Ampa packed and provided a design for VMI's MidWinter Dance on a 24ft truck of theme decor & lighting. During the production meeting a team of 6 full-time theatre technician along with managers were briefed via a detailed installation floorpan. Truck arrived onsite at 8am and project was completed by 4pm with internal staff.

General labor for the install of massive amount of massive amount of tables and chairs for any project is conducted by hired labor while managers and technicians supervising the whole install. A significant quantity of labor is ordered to allow for a complete installation by at least 1hr in advance or as designated by client before doors open.

Sample Quote



PROPOSAL

Page 1 of 6

ampa events

6701 Janway Rd, Henrico, VA 23228
info@ampaevents.com

Client: MGM National Harbor

Contact: Aedrian Aquino
Address: 101 MGM National Avenue
National Harbor, MD 20745
Phone: (702) 845-7057
Email: AEAQUINO@mgnnationalharbor.com

Job #: 14602
Agent: Ted Rubis

Event Site:
Event Date: Monday, 01/27/25
Load In: 01/27/25
Load Out: 01/27/25

Lunar New Year - VIP Dinner

I. Entrance: Drape Swages (2 sided & 2 sections w/ 1 for each door), Cut Wood Columns, Gold Bamboo in Urn w/ Fronds:

	<u>Qty.</u>	<u>Retail</u>	<u>%</u>	<u>Extended</u>	<u>Total</u>
1. Bamboo: Golden Bamboo Size: x 96" x	14	\$2.50		\$2.50	\$35.00
2. Urns: Black Metal Geo Urn (42") with Palms and Bamboo Size: 16 x 96 x 16 Color: black	2	\$175.00		\$175.00	\$350.00
					
3. Pipe and Drape: Panne Velvet, Red 14' H x 10' W Size: x x Color: red	2	\$110.00		\$110.00	\$220.00
					
4. Pipe and Drape: Panne Velvet, Red 14' H x 10' W Size: x x Color: red	2	\$110.00	60.00%	\$44.00	\$88.00
					
5. Pipe and Drape: Panne Velvet, Red 14' H x 10' W Size: x x Color: red	2	\$110.00		\$110.00	\$220.00
					
6. Pipe and Drape: Panne Velvet, Red 14' H x 10' W Size: x x Color: red	2	\$110.00	60.00%	\$44.00	\$88.00
					

Prices herein are valid for 10 days. Inventory items, Labor rates and trucking rates are subject to availability at the time the signed contract and deposit are received at Ampa.

06/26/25

Sample Quote





AMPA EVENTS
MGM National Harbor - Lunar New Year - VIP Dinner - Monday, 01/27/25

Page 2 of 6

7. Decor: Tassel, Medium Gold Size: x x Color: gold	6	\$5.00	\$5.00	\$30.00	
8. Chinese Lucky Paper Fan Kit 8-16" Size: x x	2	\$20.00	\$20.00	\$40.00	
9. Oriental Lantern Stand 8ft Size: 2x8 Choose lanterns separately	4	\$100.00	\$100.00	\$400.00	
10. Chinese Silk Lanter 16" Size: x x	6	\$20.00	\$20.00	\$120.00	
11. Screen: Oriental Bifold, Wood Frame & Gold Square Pattern Size: 24 x 95 x 24	1	\$225.00	\$225.00	\$225.00	
12. Column: Oriental Gold Square Pattern Black Frame Size: x x	2	\$375.00	\$375.00	\$750.00	
Entrance: Drape Swages (2 sided & 2 sections w/ 1 for each door), Cut Wood Columns, Gold Bamboo in Urn w/ Fronds Subtotal:				\$2,566.00	

II. Stage Set - Custom Design & Build: Center Wall 8x10x2ft (NOT White) w/ Round Detail; Chinese Wood Lattice Elements x 4; Banner Walls 2x8; Live Plants and Tall Orchid Trees:

	<u>Qty.</u>	<u>Retail</u>	<u>%</u>	<u>Extended</u>	<u>Total</u>	
1. Stage Set: Wealth Character w/Roof & Stoop 8x10x2 Size: 8x10x2	1	\$1,995.00		\$1,995.00	\$1,995.00	
2. Screen: Oriental Bifold, Wood Frame & Gold Square Pattern Size: 24 x 95 x 24	6	\$225.00		\$225.00	\$1,350.00	

Prices herein are valid for 10 days. Inventory items, Labor rates and trucking rates are subject to availability at the time the signed contract and deposit are received at Ampa.



06/26/25

Sample Quote



AMPA EVENTS
MGM National Harbor - Lunar New Year - VIP Dinner - Monday, 01/27/25

Page 3 of 6

3. Oriental Lantern Holder Size: 2x8 Choose lanterns separately	4	\$100.00		\$100.00	\$400.00
4. Centerpiece: Floral Stem Holder 72" Size: x 72 x Color: black Select floral separately	2	\$85.00		\$85.00	\$170.00
5. Red Orchid Stem 36" Size: x 36 x	88	\$3.50		\$3.50	\$308.00
6. Pipe and Drape: Polyknit, Chocolate 14' H x 10' W Section Size: 120 x 168 x 2 Color: BROWN	4	\$100.00		\$100.00	\$400.00
7. Chinese Silk Lanter 16" Size: x x	12	\$20.00		\$20.00	\$240.00
8. Floral: Orange Orchid, Phalaenopsis Stem 35" Size: x 35 x Color: Orange 35" Orange Real Touch Phalaenopsis Orchid	88	\$0.00		\$0.00	\$0.00
9. Bamboo Tree 5ft Size: 5ft	6	\$50.00	100.00%	\$0.00	\$0.00

Stage Set - Custom Design & Build: Center Wall 8x10x2ft (NOT White) w/ Round Detail; Chinese Wood Lattice Elements x 4; Banner Walls 2x8; Live Plants and Tall Orchid Trees Subtotal: \$4,863.00

III. Lighting Design, Full Room with 36 UpLights :

	Qty.	Retail	%	Extended	Total
1. Lighting Design: Full Room, Large Size: x x	1	\$3,000.00		\$3,000.00	\$3,000.00



Prices herein are valid for 10 days. Inventory items, Labor rates and trucking rates are subject to availability at the time the signed contract and deposit are received at Ampa.

06/26/25

Sample Quote



AMPA EVENTS
MGM National Harbor - Lunar New Year - VIP Dinner - Monday, 01/27/25

Page 4 of 6

2. Lighting: LED MIRAGE QA Wireless, Black Size: x x Color: black	24	\$0.00
--	----	--------

Lighting Design, Full Room with 36 UpLights Subtotal: \$3,000.00

IV. Table Linens:

	<u>Qty.</u>	<u>Retail</u>	<u>%</u>	<u>Extended</u>	<u>Total</u>
1. Linen Budget See notes for details	40	\$65.00		\$65.00	\$2,600.00

Table Linens Subtotal: \$2,600.00

V. Bar: Mahogany, or Oriental w/ Gold Lattice and Wealth Symbol. All bars are the same price. Counter Centerpieces found in Centerpiece section:

	<u>Qty.</u>	<u>Retail</u>	<u>%</u>	<u>Extended</u>	<u>Total</u>
1. Bar: Oriental Lattice & Wealth Symbol Gold, Red, Black Size: 96 x 42 x 30	3	\$575.00		\$575.00	\$1,725.00



Bar: Mahogany, or Oriental w/ Gold Lattice and Wealth Symbol. All bars are the same price. Counter Centerpieces found in Centerpiece section Subtotal: \$1,725.00

VI. Room at Large Decor - Wealth Symbol Wood Stain:

	<u>Qty.</u>	<u>Retail</u>	<u>%</u>	<u>Extended</u>	<u>Total</u>
1. Screen: Oriental Round Wealth Symbol Gold Size: 8	6	\$325.00		\$325.00	\$1,950.00



2. Urns: Black Metal Geo Urn (42") with Palms and Bamboo Size: 16 x 96 x 16 Color: black	6	\$175.00		\$175.00	\$1,050.00
---	---	----------	--	----------	------------



Prices herein are valid for 10 days. Inventory items, Labor rates and trucking rates are subject to availability at the time the signed contract and deposit are received at Ampa.

06/26/25

Sample Quote



AMPA EVENTS
MGM National Harbor - Lunar New Year - VIP Dinner - Monday, 01/27/25

Page 5 of 6

3. Sandbags: 1/4 Size for Florals Weights Size: x x	0	\$2.50	\$2.50	\$0.00
4. Sandbag: Black 25lb, Ampa Blue Handle Size: x x Color: black/blue	0	\$2.50	\$2.50	\$0.00



Room at Large Decor - Wealth Symbol Wood Stain Subtotal: \$3,000.00

VII. Delivery, Labor and Service:

	<u>Qty.</u>	<u>Retail</u>	<u>%</u>	<u>Extended</u>	<u>Total</u>
1. DELIVERY	1	\$575.00		\$575.00	\$575.00
2. Fuel Surcharge Size: x x	1	\$50.00		\$50.00	\$50.00
3. Budget for Labor at 30% Size: x x Proposed / Estimated budget. Shall be adjusted with final order.	1	\$6,800.00	25.00%	\$5,100.00	\$5,100.00

Delivery, Labor and Service Subtotal: \$5,725.00

**VIII. EXTRAS: Live Plant, Additional Lantern Holders, Sago Palm Silks
(Red or Black Banjo Drape is \$10.00 a panel vs velvet):**

	<u>Qty.</u>	<u>Retail</u>	<u>%</u>	<u>Extended</u>	<u>Total</u>
1. Live Plant Budget Size: x x Plants by Each or By Total Budget. See notes for additional info	48	\$60.00		\$60.00	\$2,880.00
2. Oriental Lantern Stand 8ft Size: 2x8 Choose lanterns separately	6	\$100.00		\$100.00	\$600.00



Prices herein are valid for 10 days. Inventory items, Labor rates and trucking rates are subject to availability at the time the signed contract and deposit are received at Ampa.





06/26/25

Sample Quote



AMPA EVENTS
MGM National Harbor - Lunar New Year - VIP Dinner - Monday, 01/27/25

Page 6 of 6

3. Chinese Silk Lanter 16" Size: x x	12	\$20.00		\$20.00	\$240.00
					
4. Foliage: Palm, Sago (Low at 12x24in) Size: 12 x 24 x 12 Color: green	18	\$15.00	100.00%	\$0.00	\$0.00
					
5. Drape: Panel: Panne Velvet, Red 14ft Size: x x	12	\$35.00		\$35.00	\$420.00
					
6. Drape: Panel: Banjo, Black 8' Size: 4' x 8' Color: black Drape only. 48"x94"	33	\$10.00	100.00%	\$0.00	\$0.00
					
7. Support: Wood Bases w/ Holes	1	\$2.50	100.00%	\$0.00	\$0.00
					

EXTRAS: Live Plant, Additional Lantern Holders, Sago Palm Silks (Red or Black Banjo Drape is \$10.00 a panel vs velvet) Subtotal: \$4,140.00

Subtotal Nontaxable	\$8,591.50
Subtotal Taxable	\$21,894.00
Subtotal	\$30,485.50
6% Sales Tax	\$1,313.64
Retail Total	\$31,799.14
Courtesy Deduction	<\$2,866.50 >
Grand Total	\$28,932.64

Sample Invoice



AMPA EVENTS
6701 JANWAY RD
HENRICO, VA 23228
54-1886661

Invoice

DATE	INVOICE NO.
1/3/2025	5-28792

Ph 800-358-5451 - Fax 804-358-0572
WWW.AMPAEVENTS.COM

PAID
02/14/2025

MGM National Harbor
Aedrian Aquino
1010MGM National Ave
National Harbor, MD 20745

SHIP TO

Rep	P.O. No.	Ampa Job	Terms	Event Date
TCR	C11328059	14602	50% Deposit Due Now	1/27/25

DESCRIPTION	QTY	RATE	AMOUNT
Rental Fees for Product for the LUNAR NEW YEAR VIP EVENT - 1/27/25	1	21,894.00	21,894.00
Labor for Installation and Removal	1	5,100.00	5,100.00
Delivery and Fuel sur-charge	1	625.00	625.00

PLEASE REMIT TO:
Ampa Events
6701 Janway Road
Henrico, VA 23228

Subtotal	\$27,619.00
Sales Tax (6.0%)	\$1,313.64
Total	\$28,932.64
Payments/Credits	-\$28,932.64
Balance Due	\$0.00

- h. Understanding Commonwealth of Virginia Higher Education requirements for Commencement Support for the same or similar timeframes, describe your capacity to meet that demand signal.



Production timeframes and maintaining appropriate schedules are independent of event type setup parameters including short installation on quick turnaround projects are managed by advanced planning and the development of an execution program to meet client's goals.

- i. Describe any proposed subcontracting arrangements and expectations.



DC Rental

Products: Linens, China, Flatware, Glassware, Bulk Decorative Ballroom Chairs

ALL PRODUCTS HEREIN PROVIDED AT MARKET COSTS W/ NO ADDITIONAL MARKUP TO DC RENTAL'S RETAIL PRICE OTHER THAN DELIVERY & LABOR

Brooks Rentals - Vienna, Va

Products: Tents, bulk chairs, tables

ALL PRODUCTS HEREIN PROVIDED AT MARKET COSTS W/ NO ADDITIONAL MARKUP

- j. Describe your inclement weather procedures.



Safety first is the most important SOP. Each type of equipment may have different requirements. High wind action plans are developed for some project. Most equipments, such as tents, are installed to withstand weather events. The best approach is to have a clear understanding of a day by which the event is CALLED and moved indoors. In this day of instant access to weather information, a surprise storm is a rare occurrence.

In general Action Plans are develop for each event in the planning phase. Staff may be planned for in advance with a clear scope of duties while onsite during the event.



- a. Complete pricing schedule attached (attachment 3) filling in pricing for all items that your company can provide.



See Attachment 3 on page 51

- b. Identify any offered discounts, rebates, opportunities for internships, sponsorships.



The following elements shall be provided with a 10% courtesy rate:
Lounge Furniture, Designer Bars, and Theme Decor.

- c. Identify any add-on charges proposed in complete detail (shipping by order, by load; by delivery; split order add-on charges; cancellation fees; credit card fees). Any add-on charges that are not identified in your original proposal will not be permitted under a resulting contract. It is imperative that you identify all potential add-on charges for consideration.



Credit Card Fee = 3%
 Delivery by Truck Size - per round trip
 24ft and 16ft = 275.00
 Econo Van and Pick up Truck = 175.00
 Cancellation Fee - we do not have an added fee, but this is governed
 by the negotiated contract terms prior to signing a contract.

ATTACHMENT 3-- PRICING SCHEDULE

RETURN THIS FORM WITH YOUR PROPOSAL PACKAGE

The Contractor agrees to provide the services in compliance with the scope of work for each specific line item/services at a firm fixed price for the period of this agreement as follows.

In any instance where the contractor cannot provide the required services within an acceptable timeframe, the University reserves the right to purchase these services on the open market.

The quantities are estimated quantities used for evaluation purposes only. The University reserves the right to purchase those services actually needed and in quantities as required by the University regardless of whether such total quantities are more or less than those shown.

Item No	Description	Daily Rental	Quantity	Unit	Total
	TENTS and Canopies (Provide, Install, and Remove)				
	To include poles and concrete anchors, courtyard tents (all require concrete anchors)				
1	Tents, 10' x 10', Standard Tent	\$ 145		Each	\$
2	Tents, 10' x 10', High Peaked	\$		Each	\$
3	Tents, 15' x 15'	\$ 330			
4	Tents, 15' x 30'	\$ 465		Each	\$
5	Tents, 20' x 20'	\$ 425		Each	\$
6	Tents, 30' x 30'	\$ 850		Each	\$
7	Tents, 30' x 40'	\$ 995		Each	\$
8	Tents, 30' x 45'	\$ 920		Each	\$
9	Tents, 30' x 50'	\$		Each	\$
10	Tents, 30' x 60'	\$ 1250		Each	\$
11	Tents, 30' x 75'	\$		Each	\$
12	Tents, 40' x 80'	\$ 2100		Each	\$
13	Tents, 60' x 100'	\$ 3800		Each	\$
14	Tents, 80' x 100'	\$		Each	\$
15	Tents, 80' x 210"	\$		Each	\$
16	Clear Top Tent, 30' x 30'	\$		Each	\$
17	Clear Top Tent, 30' x 40'	\$		Each	\$
18	Clear Top Tent, 30' x 45'	\$		Each	\$
19	Clear Top Tent, 30' x 50'	\$		Each	\$
20	Clear Top Tent, 30' x 60'	\$		Each	\$
21	Clear Top Tent, 30' x 30'	\$		Each	\$
22	Clear Top Tent, 30' x 75'	\$		Each	\$
23	Clear Top Tent, 30' x 90'	\$		Each	\$
24	Clear Top Tent, 40' x 45'	\$		Each	\$
25	Clear Top Tent, 40' x 50'	\$		Each	\$
26	Clear Top Tent, 40' x 60'	\$ 2992.50		Each	\$
27	Clear Top Tent, 40' x 80'	\$ 3375		Each	\$
28	Clear Top Tent, 40' x 100'	\$ 3765		Each	\$
29	Clear Peak Tent, 10' x 10'	\$		Each	\$
30	Clear Peak Tent, 10' x 20'	\$		Each	\$
31	Clear Peak Tent, 15' x 15'	\$		Each	\$
32	Clear Peak Tent, 20' x 20'	\$		Each	\$

33	Clear Peak Tent, 20' x 30'	\$		Each	\$
34	Clear Peak Tent, 20' x 40'	\$		Each	\$
35	Sail Cloth Tent, 45' x 44'	\$		Each	\$
36	Sail Cloth Tent, 45' x 64'	\$		Each	\$
37	Sail Cloth Tent, 45' x 84'	\$		Each	\$
38	Sail Cloth Tent, 45' x 104'	\$		Each	\$
TENT Accessories (Provide, Install, and Remove)					
39	Concrete Anchors	\$ 12.00		Each	\$
40	Concrete Covers	\$		Each	\$
41	Tent Pole Covers	\$ 20.00		Each	\$
42	Tent Liner for Each Size Tent	\$		Each	\$
43	Tent Lights, Bistro – Black and White	\$		Each	\$
44	Tent Lights, Lanterns, Japanese 12", 16", 20" and 24"	\$ 15-20.00		Each	\$
45	Tent Fan	\$ 110		Each	\$
46	Tent Fan - 12"	\$		Each	\$
47	Tent Fan – 18"	\$		Each	\$
48	Drum Fan, 24"	\$		Each	\$
49	Tent Gutter	\$ 15.00		Each	\$
TABLES (Rental, Set-up, Breakdown)					
50	Banquet Rectangular 4' x 30"	\$ 6.90		Each	\$
51	Banquet Rectangular 6' x 30"	\$ 8.10		Each	\$
52	Banquet Rectangular 8' x 30"	\$ 8.60		Each	\$
53	Banquet Rectangular 6' x 18"	\$		Each	\$
54	Banquet Rectangular 8' x 18"	\$		Each	\$
55	Banquet Rectangular 8' x 30" Children's Table	\$		Each	\$
56	Banquet Round 3'	\$ 7.80		Each	\$
57	Banquet Round 4'	\$ 12.50		Each	\$
58	Banquet Round 5'	\$ 15.50		Each	\$
59	Banquet Round 6'	\$ 16.00		Each	\$
60	Cocktail Rounds Tall and Standard Heights 24"	\$ 10.75		Each	\$
61	Cocktail Rounds Tall and Standard Heights 30"	\$ 11.85		Each	\$
62	Square 2', Standard and High Top	\$ 25.00		Each	\$
63	Square 4', Standard	\$ 35.00		Each	\$

64	Square 5', Standard	\$ 45.00		Each	\$
65	Serpentine 8'	\$ 11.00		Each	\$
66	Timberwood Farm Table, 4' x 8'	\$ 145.00		Each	\$
67	Timberwood Benches for Farm Table	\$		Each	\$
68	King Table, 4' x 8' Rectangular Table	\$		Each	\$
CHAIRS (Rental, Set-up, Breakdown)		\$		Each	\$
69	Padded Garden, White, Black and Natural	\$ 4.00		Each	\$
70	Folding Black, White, and Tan	\$ 1.50		Each	\$
71	Chivari Barstool, Black and Natural, mahogany,	\$ 17.00		Each	\$
72	Chivari Black, Gold, Silver, Mahogany, and White	\$ 17.00		Each	\$
73	Set Up/Knock Down of Chairs	\$		Each	\$
STAGE SECTIONS, 4' X 8' (PROVIDE, INSTALL, AND REMOVE)					
74	Stage, 12" High	\$ 50.00		Each	\$
75	Stage, 32" High	\$ 75.00		Each	\$
STAGE EQUIPMENT (PROVIDE, INSTALL AND REMOVE)					
76	Staging (Risers 4 x 4)	\$ 35/45.00		Each	\$
77	Staging Steps	\$ 162.50		Each	\$
78	Black Astroturf Covering for Stage	\$.60 sq ft		Each	\$
79	4' Guard Rails for Staging	\$ 25.00		Each	\$
80	ADA Access Ramps by the Foot	\$ 125.00		Each	\$
STAIRS (PROVIDE, INSTALL AND REMOVE)					
81	Stairs, 12" High	\$ 50.00		Each	\$
82	Stairs, 32" High	\$ 75.00		Each	\$
PIPES AND DRAPES (RENTAL ONLY)					

83	10' High Black, Navy Blue and Royal Blue, White	\$ 70.00		Each	\$
84	12' High Black, Navy Blue and Royal Blue, White	\$ 80.00		Each	\$
85	20' High Black, Navy Blue and Royal Blue, White	\$ 125.00		Each	\$
STANCHIONS (RENTAL ONLY)					
86	36" High, without Rope	\$ 15/25.00		Each	\$
87	White Plastic with White Plastic Chain	\$		Each	\$
STANCHIONS CHROME PORTA POST					
88	6' Section Red and Black Velour Rope	\$ 15.00		Each	\$
89	8' Section Red and Black Velour Rope	\$		Each	\$
ARCHES (PROVIDE, INSTALL AND REMOVE)					
90	Wood	\$ 97.50		Each	\$
COLUMN (PROVIDE, INSTALL AND REMOVE)					
91	33"	\$ 45.00		Each	\$
92	46"	\$ 45.00		Each	\$
93	56"	\$ 25.00		Each	\$
94	76"	\$ 65.00		Each	\$
95	Stage Façade, 3' x 4'	\$		Each	\$
96	Bar Top for Rectangular Table and Skirting, 6'	\$		Each	\$
SCREEN (PROVIDE, INSTALL AND REMOVE)					
97	6 Panel Bi-Fold Screen, White	\$		Each	\$
LOUNGE FURNITURE (PROVIDE, INSTALL AND REMOVE)					
98	Sectional Full Sofa	\$ 292.50		Each	\$
99	Sectional Love Seat	\$ 180.00		Each	\$
100	Sectional Arm Chair	\$ 210.00		Each	\$

101	Sectional Ottoman	\$		Each	\$
FLOORING (PROVIDE, INSTALL AND REMOVE)					
102	Deck Flooring	\$ 1.55 sq ft		Each	\$
103	Dance Floor	\$ 1.75 sq ft		Each	\$
104	25' Red Carpet	\$ 50.00		Each	\$
105	50' Red Carpet	\$ 75.00		Each	\$
MISCELLANEOUS (PROVIDE, INSTALL AND REMOVE)					
106	6' Bar Tops for Rectangular Tables	\$		Each	\$
107	Portable Bar	\$ 150.00		Each	\$
BAR					
108	Portable Acrylic Bar	\$ 575.00		Each	\$
COMMENCEMENT STAGING	See requirements for staging along with diagrams (Reference Attachment 7 to this RFP)	\$		Each	\$
DELIVERY		(Per Order)	(Flat Rate)		
109	Delivery and Pickup Charge, Flat Rate, for Chairs, Tables, Pipe and Drapes, Stanchions, and other items as Required.	\$ 575.00	\$	Events	\$
TOTAL NET PRICING:					
110	Informational Pricing: The Contractor offers to the University the following discount from the contractor's standard published list price in effect at the time of the rental for all items not listed above % - Listed Price				

ATTACHMENT 4 -- SMALL BUSINESS SUBCONTRACTING PLAN
MUST BE COMPLETED AND RETURNED WITH PROPOSAL

All small businesses must be certified by the Commonwealth of Virginia, Department of Small Business and Supplier Diversity (DSBSD) by the due date of the solicitation to participate in the SWaM program. Certification applications are available through DSBSD online at <http://sbsd.virginia.gov>.

DEFINITIONS:

“Micro Business” means a business that is a certified Small Business under the SWaM Program and has no more than twenty-five (25) employees and no more than \$3million in average annual revenue over the three-year period prior to their certification.

“Small business” means a business independently owned and controlled by one or more individuals who are U.S. citizens or legal resident aliens, and together with affiliates, has 250 or fewer employees, or average annual gross receipts of \$10 million or less averaged over the previous three years. One or more of the individual owners shall control both the management and daily business operations of the small business. *Note: DSBSD-certified women- and minority-owned businesses shall also be considered small businesses when they have received DSBSD small business certification. (Code of Virginia, § 2.2-4310)*

“Woman-owned business” means a business that is at least 51% owned by one or more women who are U.S. citizens or legal resident aliens, or in the case of a corporation, partnership, or limited liability company or other entity, at least 51% of the equity ownership interest is owned by one or more women who are U.S. citizens or legal resident aliens, and both the management and daily business operations are controlled by one or more women. *(Code of Virginia, § 2.2-4310)*

“Minority-owned business” means a business that is at least 51% owned by one or more minority individuals who are U.S. citizens or legal resident aliens, or in the case of a corporation, partnership or limited liability company or other entity, at least 51% of the equity ownership interest in the corporation, partnership, or limited liability company or other entity is owned by one or more minority individuals who are U.S. citizens or legal resident aliens, and both the management and daily business operations are controlled by one or more minority individuals. *(Code of Virginia, § 2.2-4310)*

Bidder Name: Theodore Rubis

Preparer Name: James Meekins **Date:** 6/26/2025

INSTRUCTIONS:

- A. If you are certified by the Department of Small Business and Supplier Diversity (DSBSD) as a small business, complete only Section A of this form. This shall not exclude DSBSD-certified women-owned and minority-owned businesses when they have received DSBSD small business certification.
- B. If you are not a DSBSD-certified small business, complete Section B of this form. For the bid to be considered and the bidder to be declared responsive, the bidder shall identify the portions of the contract that will be subcontracted to DSBSD-certified small business in Section B.

ATTACHMENT 4 (CONT'D)

Section A

If you are certified by the Department of Small Business and Supplier Diversity (DSBSD), are you certified as a:

Check All That Apply: Micro Business Small Business Woman-Owned Business Minority-Owned Business

DSBSD Certification No.: SWAM 007285 Expiration Date: 1/18/2028

COMMITMENT TO SMALL BUSINESS

As an eVA small business, Ampa is committed to working with other small business and we shall seek out support from local Fredericksburg business per the event needs.

ATTACHMENT 6

SUBCONTRACTOR APPROVAL REQUEST

No portion of the work (including equipment) shall be subcontracted to another firm or individual **without prior written consent** of the University of Mary Washington. In the event that the contractor desires to subcontract some part of the work specified herein, the Contractor shall furnish the University with the names, qualifications and experience of their proposed subcontractors for agency approval. The primary contractor shall, however, remain fully liable and responsible for the work performed by its subcontractor(s) and shall assure compliance with all requirements of the contract.

List proposed subcontractor(s), including name, address, contact person, and type of work to be performed under this contract below:

Company and Individual Name and Address	Contact Person and Phone Number	Type of Work to be Performed	Type of Equipment Proposed Subcontractor will Provide	Qualifications of Proposed Subcontractor
Brooke Rental Center, Inc 321 Mill St. NE Vienna VA 22180 #720632	James C Brooke 703-938-4807 JCB@brookerental.com	Installation & Take Down	Tents & Chairs	

ADDENDUM
June 17, 2025

ADDENDUM NO. 1 TO ALL OFFERORS:

Reference – Request for Proposals: #UCPUMW 25-1937
Date Issued: June 3, 2025
For Delivery to: University of Mary Washington, Commonwealth of Virginia
Proposal Due Date: July 3, 2025

This addendum consists of one (1) pages.

Questions from Offerors:

- Question:** The stage under the 40X tent is tiered...do you know the length of the stage?
UMW Response: The length is 76 feet wide.
- Question:** The height of the stage in the back and each tiered by how many inches resulting in being what height in the front?
UMW Response: Tiers are 6" and the front level is 6" off the ground. Due to the bowl shape of the ground, the height varies across each level, but everything is taken off the front portion of the stage.
- Question:** The VIP tent...does that have any type of ground covering or no flooring of any type?
UMW Response: There is no flooring of any type.

END OF ADDENDUM NO. 1

Kenneth Manahan
Sr. Contract Officer
Procurement Services
University of Mary Washington
Phone: (540)654-1006

RFP UCPUMW 25-1937 Addendum No. 1 (and all addenda) should be acknowledged and included in the RFP submittal package.

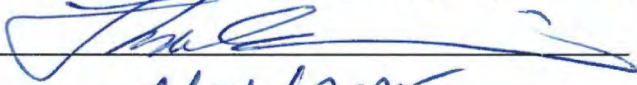
NAME OF OFFERING FIRM: Amya Events Amya Entertainment
NAME OF OFFEROR REPRESENTATIVE: Theodore C. Rubit President Inc
OFFEROR SIGNATURE: 
DATE: 6/26/2025